

TYPE	OUTPUT		POLE	TIME RATING	VOLTAGE	Hz	SYNSPEED R.P.M
	HP.	KW.					
AEH8N	200	149.2	2	CONT.	460	60	3600

TOTALLY ENCLOSED FAN-COOLED TYPE, SQUIRREL-CAGE ROTOR

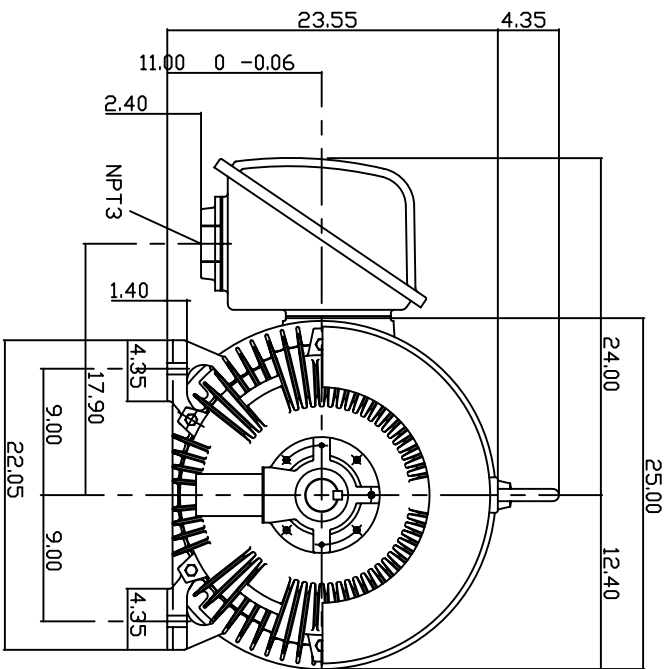
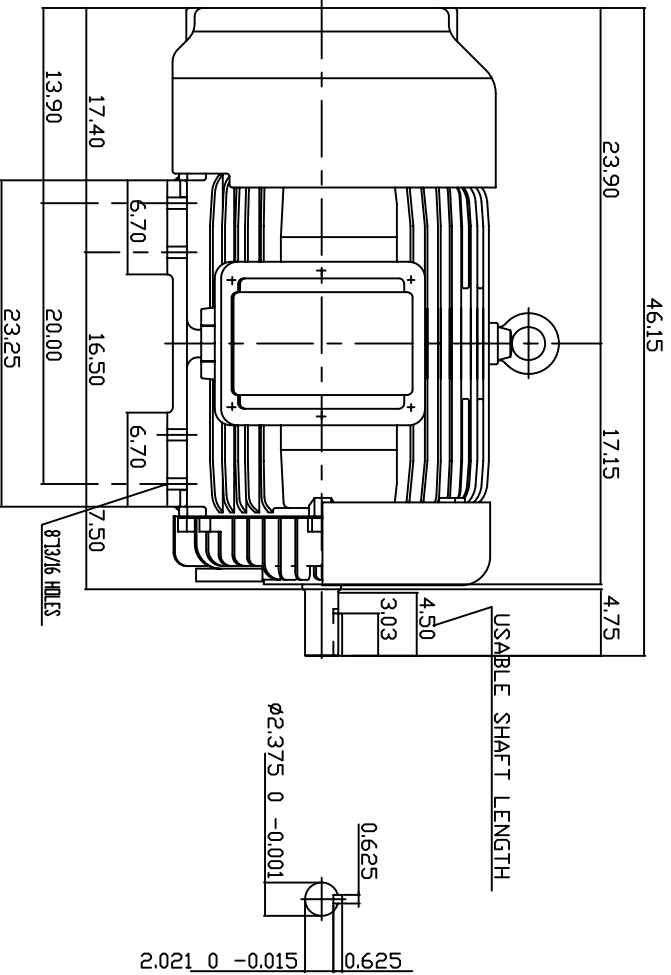

NOTE:

1. DIMENSIONS IN INCH
2. FRAME NO. 447TS
3. F CLASS INSULATION, S.F.115
4. FOR DIRECT FLEXIBLE COUPLING
5. ENCLOSURE: IP54
6. BEARING SIZE: DRIVE END: 6314C3  
NON-DRIVE END: 6314C3
7. APPROX. WEIGHT: 2150 LBS

TW-56C

DWN.	T.H.Pan	FEB 17 2005
CHKD.	H.HUANG	FEB 17 2005
APPD.	C.WANG	FEB 17 2005

DATE 20050616  
 CATALOG # EP2002  
 3-PHASE INDUCTION MOTOR



DWG NO. 3A040Y685  
 REV: 00

A

B

C

D

6

5

4

3

2

1

6

5

4

3

2

1