

TYPE	OUTPUT		POLE	TIME RATING	VOLTAGE V	Hz	SYN.SPEED R.P.M
	HP.	kW.					
AEHH8NCF	200	149.2	6	CONT.	460	60	1200

TOTALLY ENCLOSED FAN-COOLED TYPE. SQUIRREL-CAGE ROTOR

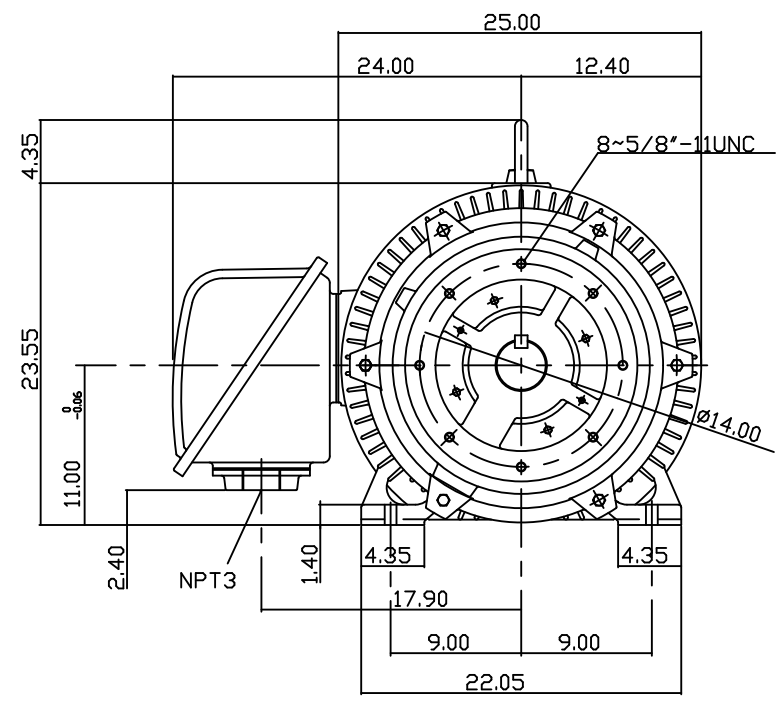
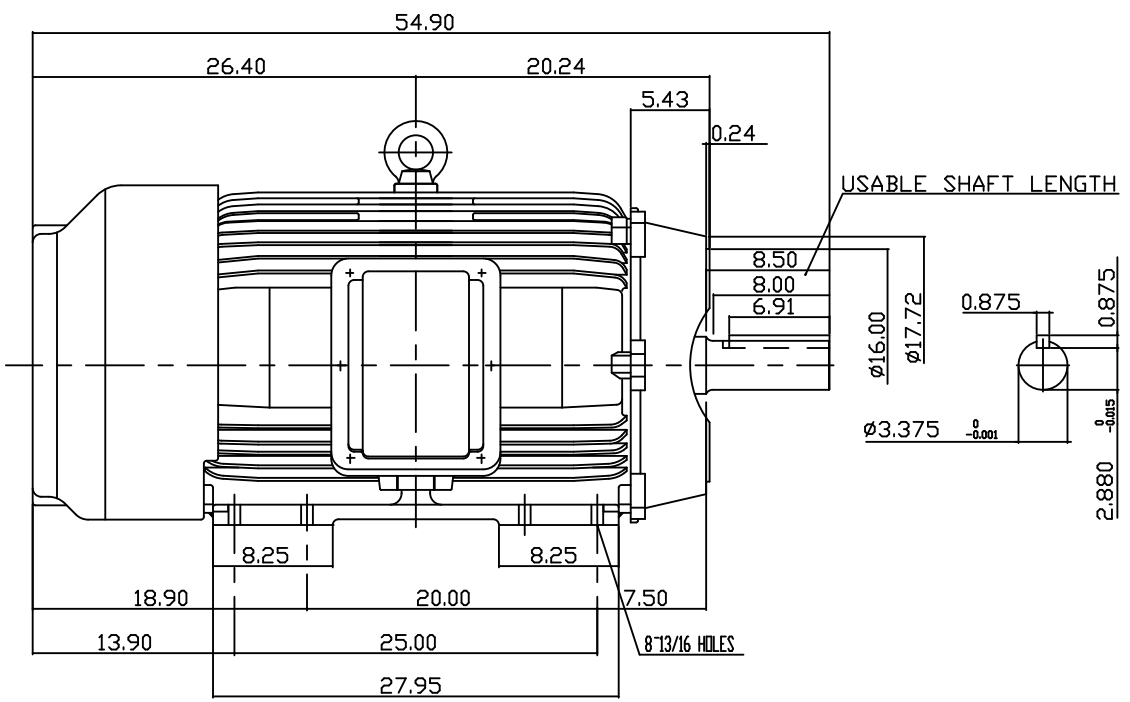

- NOTE:
1. DIMENSIONS IN INCH
 2. FRAME NO. 449TC
 3. F CLASS INSULATION, S.F.115
 4. FOR DIRECT FLEXIBLE COUPLING
 5. ENCLOSURE: IP54
 6. BEARING SIZE: DRIVE END: 6320
NON-DRIVE END: 6316
 7. APPROX. WEIGHT: 3450 LBS

TW-56C

DWN.	Y.ZHU	JAN '04 2006
CHKD.	H.HUANG	JAN '04 2006
APPD.	C.WANG	JAN '04 2006

DATE	06/21/2013	OUTLINE DIMENSIONS
CATALOG #:	EP2006C	3-PHASE INDUCTION MOTOR
TEC Westinghouse		DWG NO. REV: 00
		3B040C733