

TYPE	OUTPUT		POLE	TIME RATING	VOLTAGE V	Hz	SYN.SPEED R.P.M
	HP.	kW.					
AEHH8N	350	261.1	4	CONT.	380	50	1500

TOTALLY ENCLOSED FAN-COOLED TYPE, SQUIRREL-CAGE ROTOR

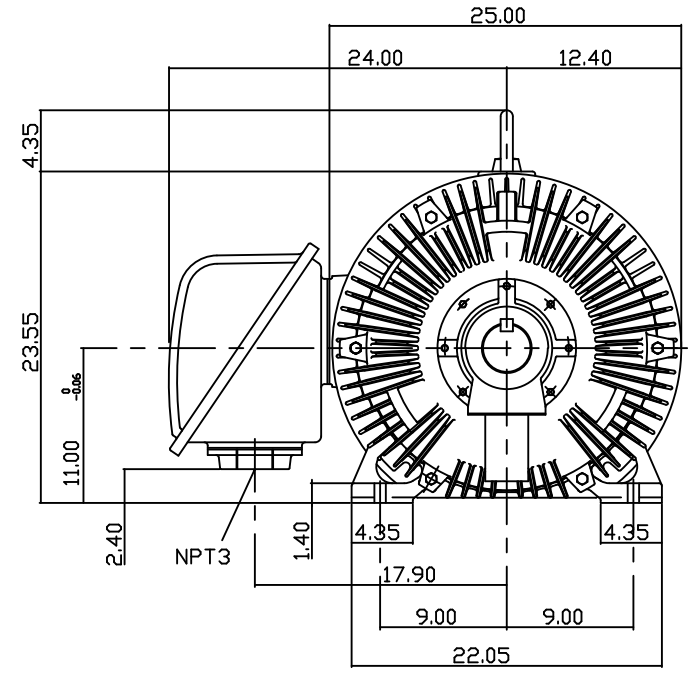
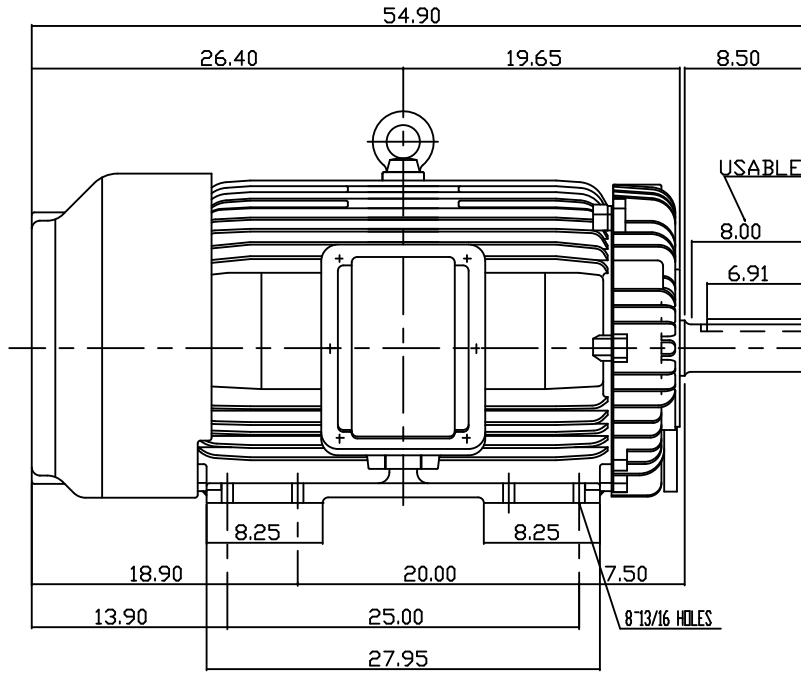

NOTE:

1. DIMENSIONS IN INCH
2. FRAME NO. 449T
3. F CLASS INSULATION, S.F.1.15
4. FOR DIRECT FLEXIBLE COUPLING
5. ENCLOSURE: IP54
6. BEARING SIZE: DRIVE END: 6320
NON-DRIVE END: 6316
7. APPROX. WEIGHT: 3450 LBS

DATE 12-17-12	OUTLINE DIMENSIONS	
CATALOG #EP3504	3-PHASE INDUCTION MOTOR	
DWG NO. 3A040Y647	REV: 00	

DWN.	J.WANG	JAN 28 2005
CHKD.	H.HUANG	JAN 28 2005
APPD.	C.WANG	JAN 28 2005

TEC Westinghouse

TW-56C