

TYPE	OUTPUT		POLE	TIME RATING	VOLTAGE	Hz	SYN SPEED R.P.M
	HP.	KW.					
AEH8N	500	373	2	CDNT.	380	50	3000

TOTALLY ENCLOSED FAN-COOLED TYPE. SQUIRREL-CAGE ROTOR

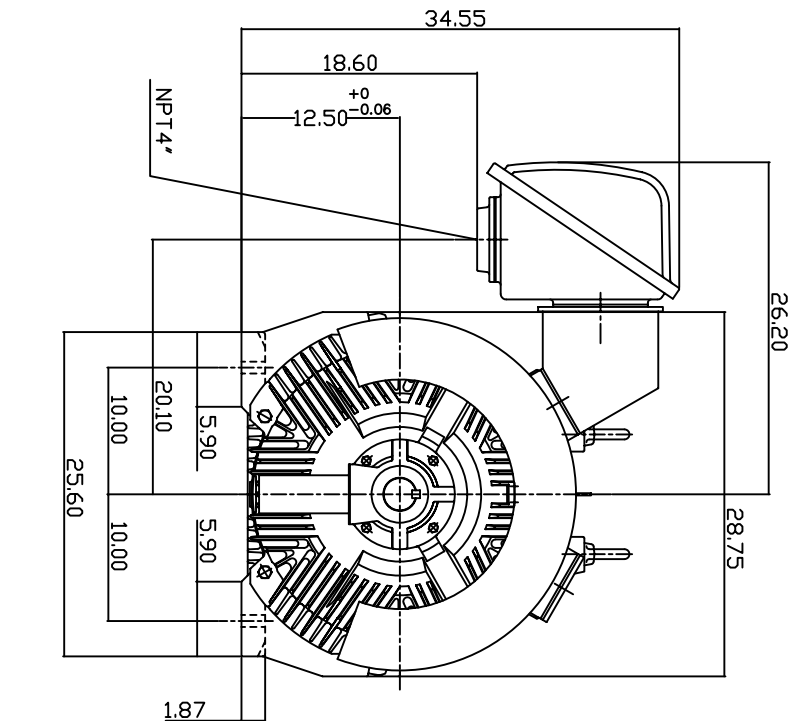
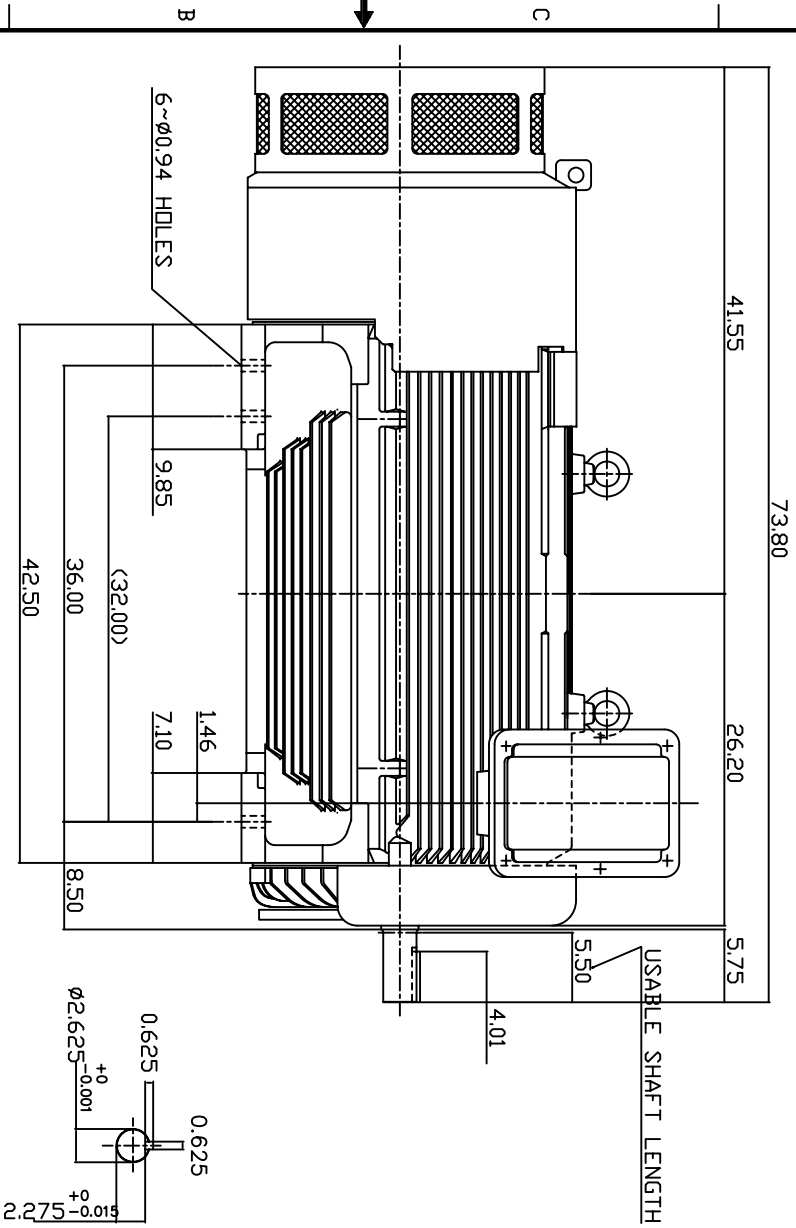

ROTATION

NOTE:

1. DIMENSIONS IN INCH.
2. FRAME NO. 5011A
3. F CLASS INSULATION, SF.1.0
4. FOR DIRECT FLEXIBLE COUPLING
5. BEARING SIZE: DRIVE END: 6315C3
NON-DRIVE END: 6315C3
6. MOTOR APPROX. WEIGHT: 4600 LBS

TV-56C

DWN.	W.LLIN	FEB. 27. 2003
CHKD.	W.LLIN	FEB. 27. 2003
APPD.	C.WANG	FEB. 27. 2003

DATE	APRIL 23, 2004
CATALOG NO.	EP5002-50

OUTLINE DIMENSIONS
3-PHASE INDUCTION MOTOR



DWG NO. 3A040T170-1
REV: 00