

**BALDOR® • RELIANCE** 

**Product Information Packet**

**FDL3510M**

**1HP,1725RPM,1PH,60HZ,56H,3524L,TEFC,F1,N**

Part Detail							
Revision:	G	Status:	PRD/A	Change #:		Proprietary:	No
Type:	AC	Elec. Spec:	35WGS245	CD Diagram:	CD0269	Mfg Plant:	
Mech. Spec:	35E2559	Layout:	35LYE2559	Poles:	04	Created Date:	03-26-2014
Base:	RG	Eff. Date:	03-09-2018	Leads:	4#16 A&J,2#18 B PH,1#14 #4TH		

Specs			
Catalog Number:	FDL3510M	Inverter Code:	Not Inverter
Enclosure:	TEFC	KVA Code:	K
Frame:	56H	Lifting Lugs:	No Lifting Lugs
Frame Material:	Steel	Locked Bearing Indicator:	No Locked Bearing
Output @ Frequency:	1.000 HP @ 60 HZ	Motor Lead Quantity/Wire Size:	4 @ 16 AWG, A&J
Synchronous Speed @ Frequency:	1800 RPM @ 60 HZ	Motor Lead Exit:	Ko Box
Voltage @ Frequency:	230.0 V @ 60 HZ	Motor Lead Termination:	Flying Leads
	115.0 V @ 60 HZ	Motor Type:	3524L
XP Class and Group:	None	Mounting Arrangement:	F1
XP Division:	Not Applicable	Power Factor:	73
Agency Approvals:	CSA	Product Family:	General Purpose
	UR	Product Type:	FARM DUTY
Auxillary Box:	No Auxillary Box	Pulley End Bearing Type:	Sealed Bearing
Auxillary Box Lead Termination:	None	Pulley Face Code:	Standard
Base Indicator:	Rigid	Pulley Shaft Indicator:	Standard
Bearing Grease Type:	Polyrex EM (-20F +300F)	Rodent Screen:	None
Blower:	None	Shaft Extension Location:	Pulley End
Current @ Voltage:	13.000 A @ 115.0 V	Shaft Ground Indicator:	No Shaft Grounding

	6.500 A @ 230.0 V	<b>Shaft Rotation:</b>	Reversible
	6.800 A @ 208.0 V	<b>Shaft Slinger Indicator:</b>	Shaft Slinger
<b>Design Code:</b>	L	<b>Speed Code:</b>	Single Speed
<b>Drip Cover:</b>	No Drip Cover	<b>Motor Standards:</b>	NEMA
<b>Duty Rating:</b>	CONT	<b>Starting Method:</b>	Direct on line
<b>Electrically Isolated Bearing:</b>	Not Electrically Isolated	<b>Thermal Device - Bearing:</b>	None
<b>Feedback Device:</b>	NO FEEDBACK	<b>Thermal Device - Winding:</b>	None
<b>Front Face Code:</b>	Standard	<b>Vibration Sensor Indicator:</b>	No Vibration Sensor
<b>Front Shaft Indicator:</b>	None	<b>Winding Thermal 1:</b>	Manual Thermal Overload
<b>Heater Indicator:</b>	No Heater	<b>Winding Thermal 1 Location:</b>	KO
<b>Insulation Class:</b>	F	<b>Winding Thermal 2:</b>	None

Nameplate NP1280L										
CAT.NO.	FDL3510M									
SPEC.	35E2559S245G1									
HP	1									
VOLTS	115/230									
AMP	13/6.5									
RPM	1725									
FRAME	56H					HZ	60		PH	1
SER.F.	1.15					CODE	K		DES	L
NEMA-NOM-EFF	67					PF	73		CL	F
RATING	40C AMB-CONT									
CC									USABLE AT 208V	6.8
DE	6205					ODE	6203			
ENCL	TEFC					SN				

Parts List		
Part Number	Description	Quantity
SA278579	SA 35E2559S245G1	1.000 EA
RA265110	RA 35E2559S245G1	1.000 EA
TPMRD4797	THERMAL 1PH 0.75 MAN REF MRD4749 T	1.000 EA
EC1645A06SP	ELEC CAP, 645-774 MFD, 125V, 2.06D X 4.	1.000 EA
NS2512A01	INSULATOR, CONDUIT BOX X	1.000 EA
35CB3007A59	35 CB .88 DIA @ 6:00, .75 MTO W/BOOT @ 3	1.000 EA
36GS1000SP	GASKET-CONDUIT BOX, .06 THICK #SV-330 LE	1.000 EA
51XB1016A07	10-16 X 7/16 HXWSSLD SERTYB	2.000 EA
11XW1032G06	10-32 X .38, TAPTITE II, HEX WSHR SLTD U	1.000 EA
HA6001A01	THERMAL RETAINER (PLATED)	1.000 EA
RM1014A01SP	BUTYL RUB.THRM COV. (MENA)	1.000 EA
51XB1214A10	12-14 X 5/8HX WS SL SR TYBX	2.000 EA
35EP3122K00	MASTER ODE,203 BRG,.683SH,#26 DRN,FH MTG	1.000 EA
51XW0832A07	8-32 X .44, TAPTITE II, HEX WSHR SLTD SE	2.000 EA
35CB4802A02SP	CAPACITOR COVER, STAMPED X	1.000 EA
35GS3001A02	GASKET, CA.COVER, 5.38 LONG .06 CS301	1.000 EA
51XB1016A05	10-16X5/16HX WA SL SR TYB (F/S)	2.000 EA
HW5100A03	WAVY WASHER (W1543-017)	1.000 EA
35EP3123G00	MASTER DE,205 BRG,1.623SH,#26 DRN	1.000 EA
HW4600B49	SEAL 0.938 X 1.624 X 0.250 SINGLE LIP DB	1.000 EA
HW4600B32SP	V-RING SLINGER 1.000 X 1.540 X .24 VITON	1.000 EA
51XB1214A16	12-14X1.00 HXWSSLD SERTYB	1.000 EA
35FH4005A32SP	IEC FH NO GRSR W/3 HOLES - PRIMED	1.000 EA
51XW1032A06	10-32 X .38, TAPTITE II, HEX WSHR SLTD S	3.000 EA

Parts List (continued)		
Part Number	Description	Quantity
35CB4521GX	CONDUIT BOX LID KIT **ORDER INDIV PARTS	1.000 EA
51XW0832A07	8-32 X .44, TAPTITE II, HEX WSHR SLTD SE	4.000 EA
HW2501D13	KEY, 3/16 SQ X 1.375	1.000 EA
HA7000A04	KEY RETAINER 0.625 DIA SHAFTS	1.000 EA
85XU0407S04	4X1/4 U DRIVE PIN STAINLESS	2.000 EA
LB1087	LABEL,MANUAL RESET (ROLL LABEL)	1.000 EA
MJ5001A27	32220KN GRAY SEALER *MIN BUY 4 QTS=1GAL	0.001 QT
WD1000A15	3-520132-2 AMP FLAG (4M/RL NON-CANC/NON-	2.000 EA
MJ1000A02	GREASE, POLYREX EM EXXON (USe 4824-15A)	0.050 LB
XY1032A02	10-32 HEX NUT DIRECTIONAL SERRATION	4.000 EA
35FN3002A05SP	EXFN, PLASTIC, 6.376 OD, .638 ID	1.000 EA
MG1025C02	WILKOFASG SG, 787.105, TAN	0.017 GA
HA3100A18	THRUBOLT 10-32 X 9.250	4.000 EA
TP5059	GENERIC THERMAL KIT	1.000 EA
SP5051A24	MODEL 35 TORQ STATIONARY SWITCH FOR "L"	1.000 EA
NS2500A02	INSULATOR, MAN THER PROT	1.000 EA
LC0269	1PH,DV,REV,THERMAL,7 LD,L.AMP THRU HTR H	1.000 EA
LB1119N	WARNING LABEL	1.000 EA
MN416A01	TAG-INSTAL-MAINT no wire (1200/bx) 5/18	1.000 EA
NP1280L	ALUM FARM DUTY UL CSA CC THERMAL	1.000 EA
36PA1000	PKG GRP, PRINT PK1016A06	1.000 EA
PE-0000002	ZRTG PE ASSEMBLY	1.000 EA
FE-0000001	ZRTG FE ASSEMBLY	1.000 EA

<b>Accessories</b>		
<b>Part Number</b>	<b>Description</b>	<b>Multiplier</b>
35-8762	C FACE KIT	A8
35EP1506A01SP	D-FLANGE KIT	A8

**AC Induction Motor Performance Data**

Record # 61934 - Typical performance - not guaranteed values

<b>Winding:</b> 35WGS245-R004	<b>Type:</b> 3524L	<b>Enclosure:</b> TEFC
-------------------------------	--------------------	------------------------

Nameplate Data				115 V, 60 Hz: Low Voltage Connection	
Rated Output (HP)	1			Full Load Torque	3 LB-FT
Volts	115/230			Start Configuration	direct on line
Full Load Amps	13/6.5			Breakdown Torque	6.6 LB-FT
R.P.M.	1725			Pull-up Torque	5.3 LB-FT
Hz	60	Phase	1	Locked-rotor Torque	9.3 LB-FT
NEMA Design Code	L	KVA Code	K	Starting Current	74 A
Service Factor (S.F.)	1.15			No-load Current	9.2 A
NEMA Nom. Eff.	67	Power Factor	73	Line-line Res. @ 25°C	0.693 Ω A Ph 1.77 Ω B Ph
Rating - Duty	40C AMB-CONT			Temp. Rise @ Rated Load	75°C
S.F. Amps				Temp. Rise @ S.F. Load	87°C
				Locked-rotor Power Factor	92.3
				Rotor inertia	0.142 LB-FT <sup>2</sup>

Load Characteristics 115 V, 60 Hz, 1 HP

% of Rated Load	25	50	75	100	125	150	S.F.
Power Factor	34	51	64	72	77	81	75
Efficiency	51.1	63	66.8	66.6	63.9	58.9	65
Speed	1781	1766	1749	1725	1697	1658	1708
Line amperes	9.4	10.2	11.4	13.4	16	19.4	15



Performance Graph at 115V, 60Hz, 1.0HP Typical performance - Not guaranteed values

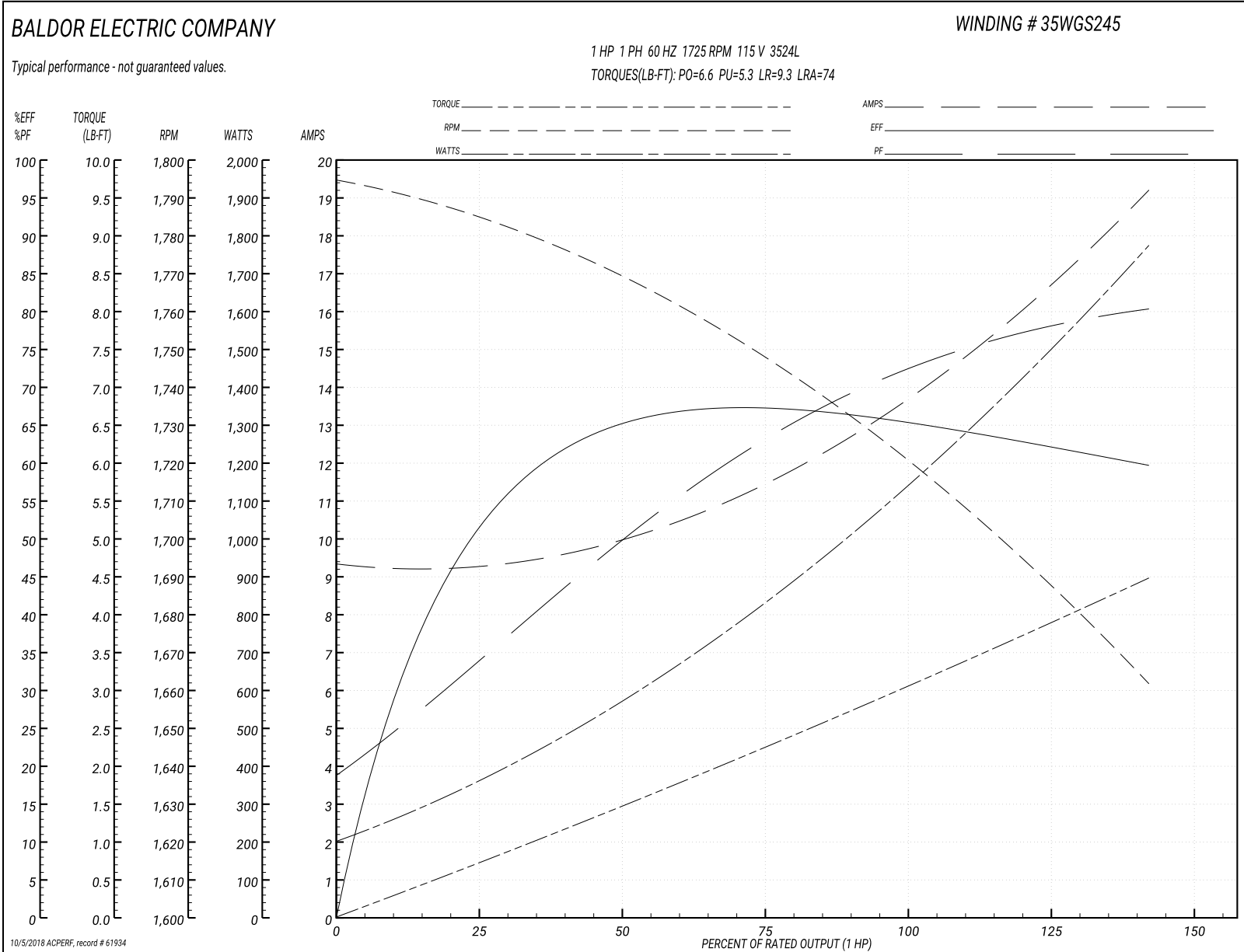

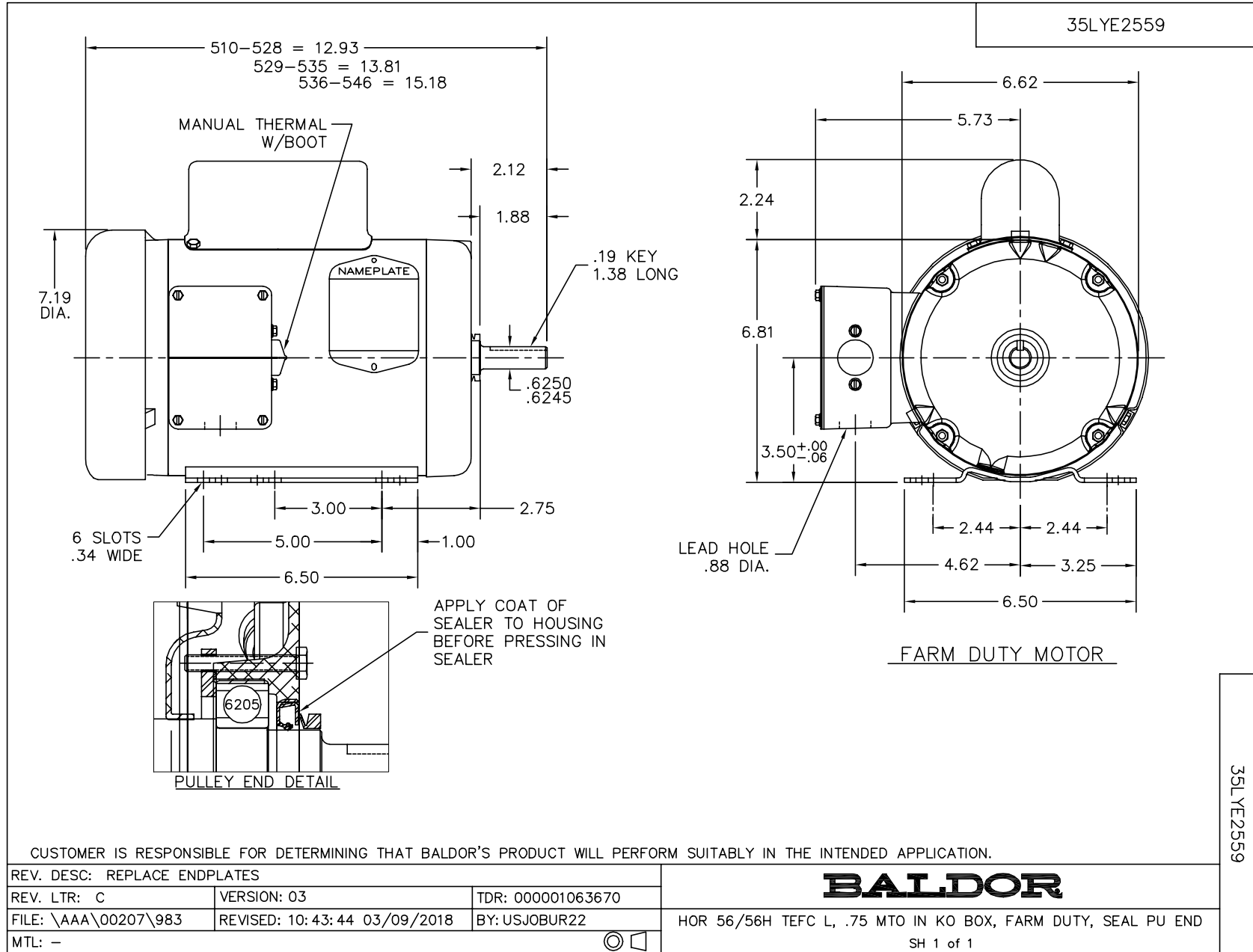

CD0269

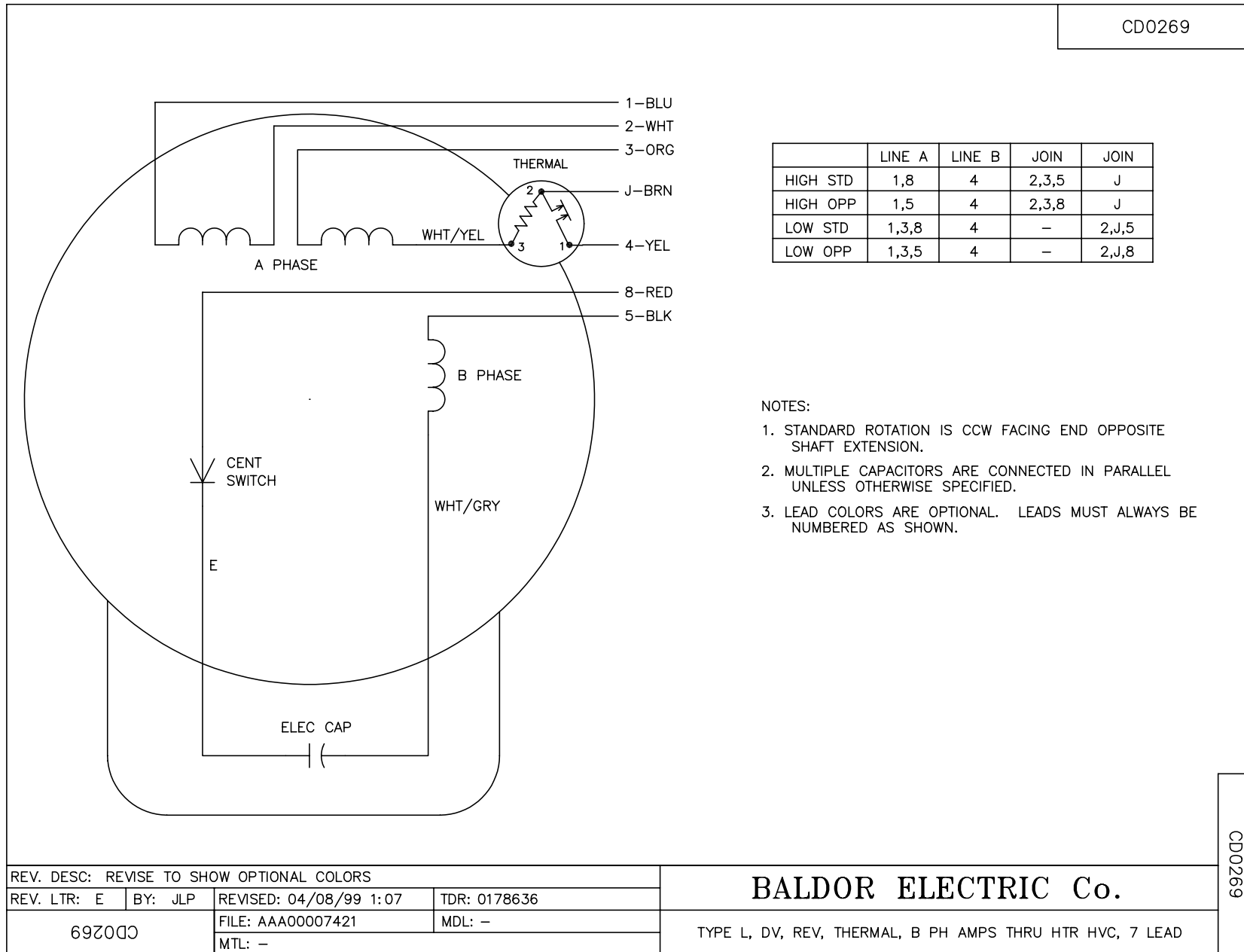

	LINE A	LINE B	JOIN	JOIN
HIGH STD	1,8	4	2,3,5	J
HIGH OPP	1,5	4	2,3,8	J
LOW STD	1,3,8	4	-	2,J,5
LOW OPP	1,3,5	4	-	2,J,8

NOTES:

1. STANDARD ROTATION IS CCW FACING END OPPOSITE SHAFT EXTENSION.
2. MULTIPLE CAPACITORS ARE CONNECTED IN PARALLEL UNLESS OTHERWISE SPECIFIED.
3. LEAD COLORS ARE OPTIONAL. LEADS MUST ALWAYS BE NUMBERED AS SHOWN.

REV. DESC: REVISE TO SHOW OPTIONAL COLORS			
REV. LTR: E	BY: JLP	REVISED: 04/08/99 1:07	TDR: 0178636
692000		FILE: AAA00007421	MDL: -
		MTL: -	

**BALDOR ELECTRIC Co.**

TYPE L, DV, REV, THERMAL, B PH AMPS THRU HTR HVC, 7 LEAD

CD0269