

FM<sup>R</sup><sub>S</sub> - 250  
1500

CUSTOMER DWG.

8-11-08

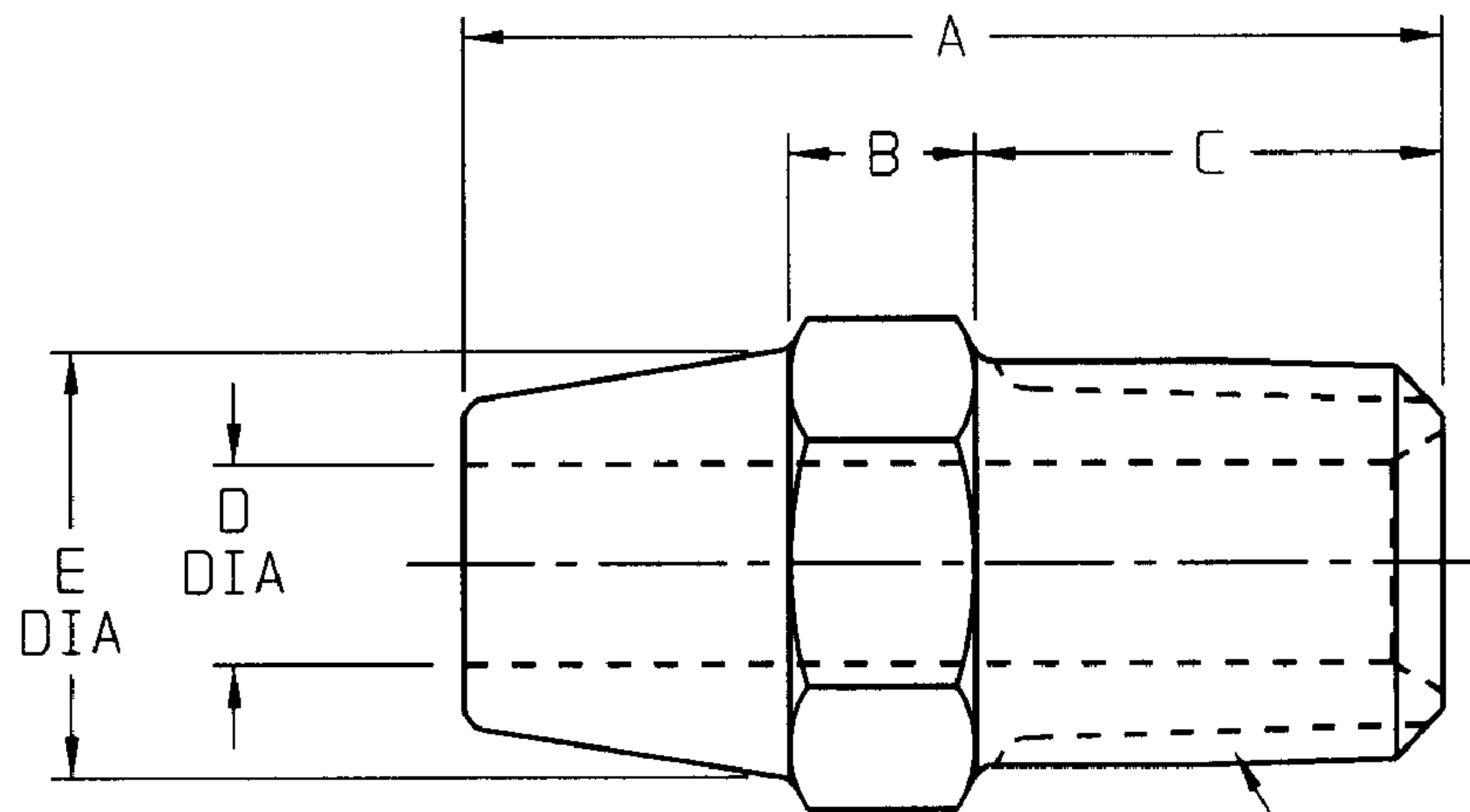
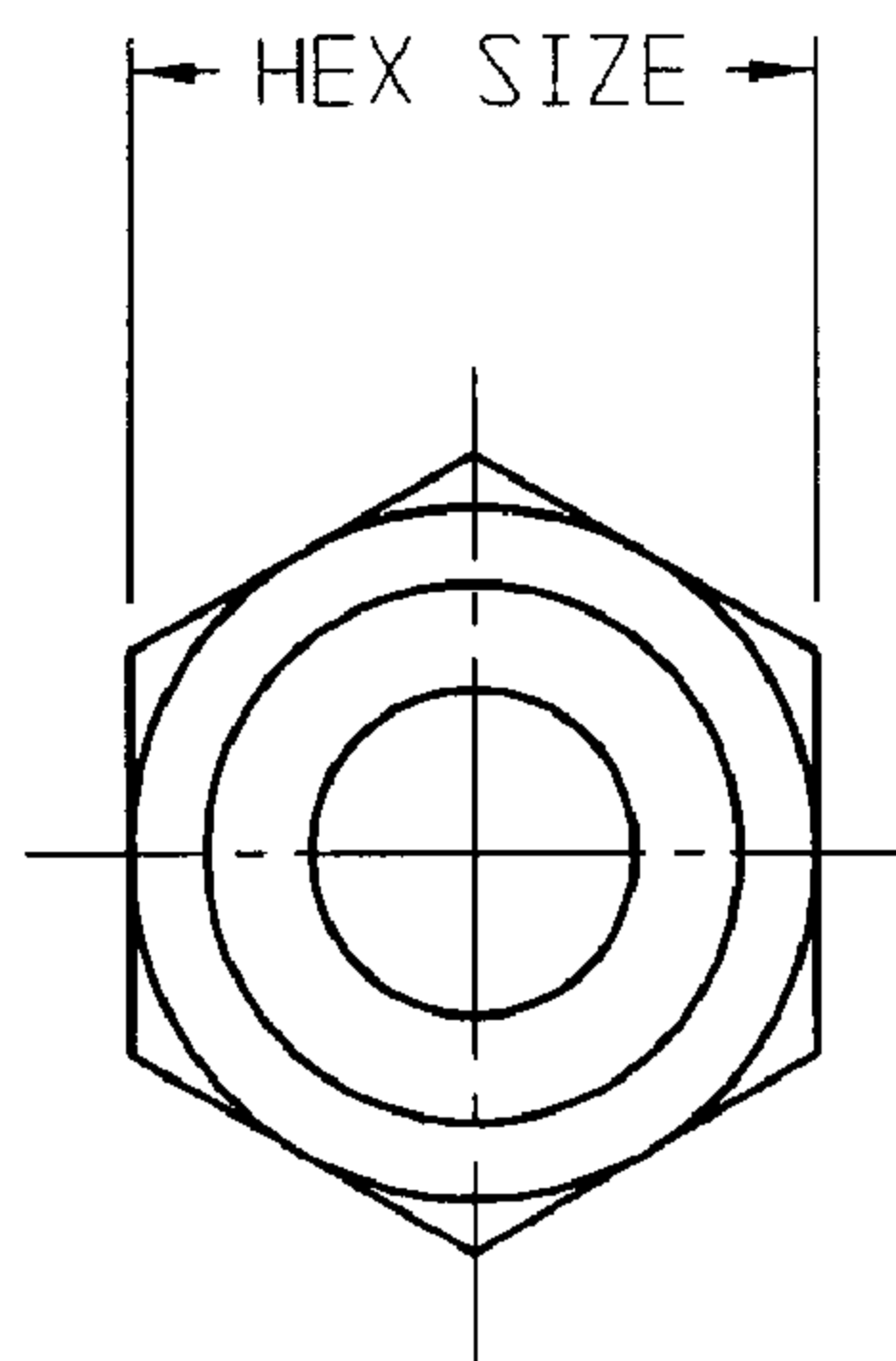

THREAD SIZE - NPT

1 1/2	FM <sup>R</sup> <sub>S</sub> -1500	CASTING	2 1/16	9/16	1 1/16	1 33/64	1 7/8	1 1/2 - 11 1/2 NPT	1 7/8
1 1/4	FM <sup>R</sup> <sub>S</sub> -1250	CASTING	2 1/16	9/16	1 1/16	1 17/64	1 7/8	1 1/4 - 11 1/2 NPT	1 7/8
1	FM <sup>R</sup> <sub>S</sub> -1000	BAR	1 13/16	3/8	1	15/16	1 5/16	1 - 11 1/2 NPT	1 5/16
3/4	FM <sup>R</sup> <sub>S</sub> -750	BAR	1 9/16	5/16	13/16	11/16	1 1/16	3/4 - 14 NPT	1 1/16
1/2	FM <sup>R</sup> <sub>S</sub> -500	BAR	1 9/16	5/16	13/16	33/64	7/8	1/2 - 14 NPT	7/8
3/8	FM <sup>R</sup> <sub>S</sub> -375	BAR	1 5/16	1/4	5/8	25/64	11/16	3/8 - 18 NPT	11/16
1/4	FM <sup>R</sup> <sub>S</sub> -250	BAR	1 5/16	1/4	5/8	17/64	9/16	1/4 - 18 NPT	9/16
SIZE	PART NO.	MATERIAL	A	B	C	D DIA	E DIA	THREAD SIZE - NPT	HEX SIZE

AGREEMENT TO MAINTAIN CONFIDENTIALITY

This drawing is owned by Dixon Valve & Coupling Co. and shall be returned upon demand. It is loaned on condition that it shall not be copied or reproduced or submitted to others without the owners consent. In accepting it subject to this condition the recipient further agrees that this drawing or any design detail or concept disclosed herein shall not be used in any way detrimental to or in competition with the owner. If the recipient does not agree to the terms of this agreement they shall return this drawing immediately.



The Right Connection™

R - 316 STAINLESS STEEL  
S - 304 STAINLESS STEEL

CUSTOMER DWG.

DIXON VALVE & COUPLING CO.  
U. S. A.

TITLE  
THREADED WELDING NIPPLES  
FOR METAL HOSE

SCALE:  
NOT TO SCALE

DRWN:  
06/01/95

APPROVAL:  
10/10/03

MAT'L STAINLESS  
STEEL

FM<sup>R</sup><sub>S</sub> - 250  
1500