

DATE
January 20, 2009
CAT. #:

OUTLINE DIMENSIONS
3-PHASE INDUCTION MOTOR

MOTOR TYPE:
AEHH8B-CF
FRAME NO. 254TC

Pole	HP	kW	Hz	VOLT	Syn.Speed r/min(rpm)
2/4/6/8	-	-	60	460	-

Ins	Rating	Dimension in	Approx Weight	Bearings
F	CONT.	inches	310 LBS	DE: 6309ZC3 NDE: 6307ZC3

Totally Enclosed Fan-Cooled Type. Squirrel-cage Rotor.

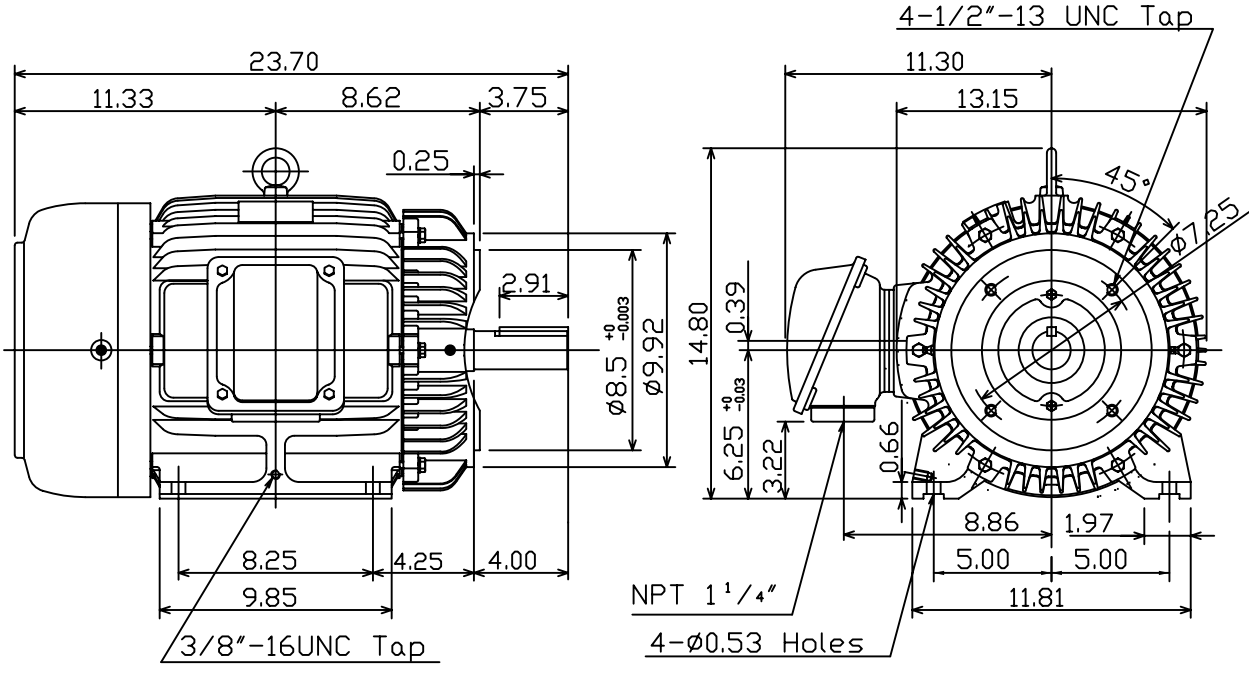

Note:
1. With Inpro Seals On Both End.

0		
---	--	--

DWN.	???????	01 07 09
CHKD.	???????	01 14 09
APPD.	???????	01 14 09



DWG NO.
31049M625660