

TYPE	OUTPUT		POLE	TIME RATING	VOLTAGE	Hz	SYN SPEED R.P.M
	HP.	KW.					
AEH8B	450	336	2	CDNT.	380	50	3000

TOTALLY ENCLOSED FAN-COOLED TYPE. SQUIRREL-CAGE ROTOR

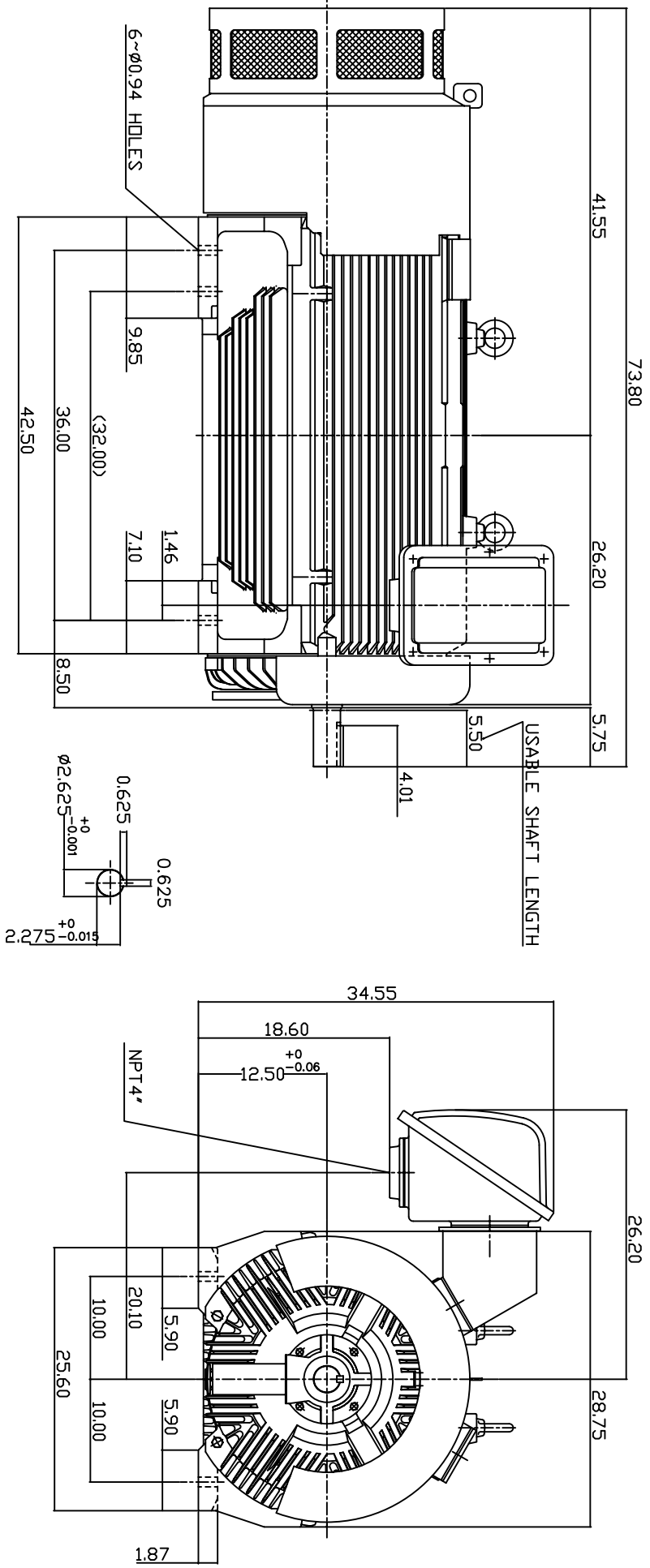

NOTE: 1. DIMENSIONS IN INCH.

2. FRAME NO. 5011A
3. F CLASS INSULATION, SF.10
4. FOR DIRECT FLEXIBLE COUPLING DRIVE END: 6315C3
5. BEARING SIZE: NON-DRIVE END: 6315C3

6. MOTOR APPROX. WEIGHT: 4200 LBS
7. ENCLOSURE: IP55
8. INPRD SEAL ON BOTH ENDS.
9. NON-SPARKING FAN.
10. NOISE BELOW 83 DBA AT 1 METER AT NO LOAD.
11. VIBRATION VERTICAL/HORIZONTAL BELDW 0.08 IN/SEC AXIAL BELDW 0.06 IN/SEC.

TV-56C

DWN.	W.LLIN	FEB. 27. 2003
CHKD.	W.LLIN	FEB. 27. 2003
APPD.	C.WANG	FEB. 27. 2003

DATE	OUTLINE DIMENSIONS
DEC 22, 2007	3-PHASE INDUCTION MOTOR
CATALOG NO.	DWG NO.
HB4502-50	3A040T170-1



REV: 00