

DATE
January 21, 2009
CAT. #:

OUTLINE DIMENSIONS
3-PHASE INDUCTION MOTOR

MOTOR TYPE:
AEUH8B-DC
FRAME NO. 324TC

Pole	HP	kW	Hz	VOLT	Syn.Speed r/min(rpm)
4/6/8

Ins	Rating	Dimension in	Approx Weight	Bearings	
F	CONT.	inch	687 LBS	DE: 6312ZC3	NDE: 6212ZC3

Totally Enclosed Fan-cooled Vertical Type.Squirrel-cage Rotor.

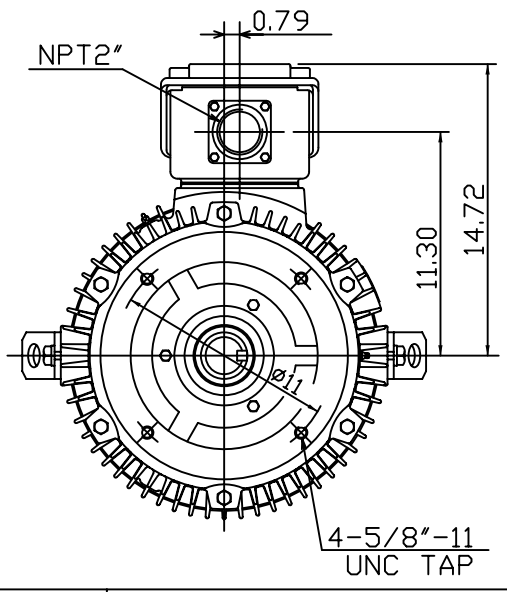
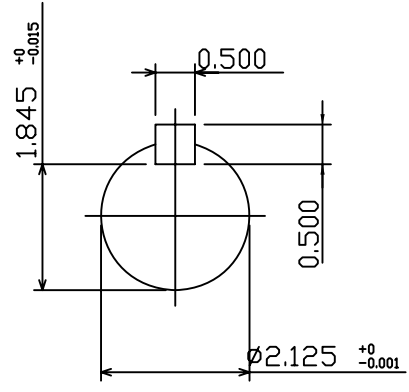
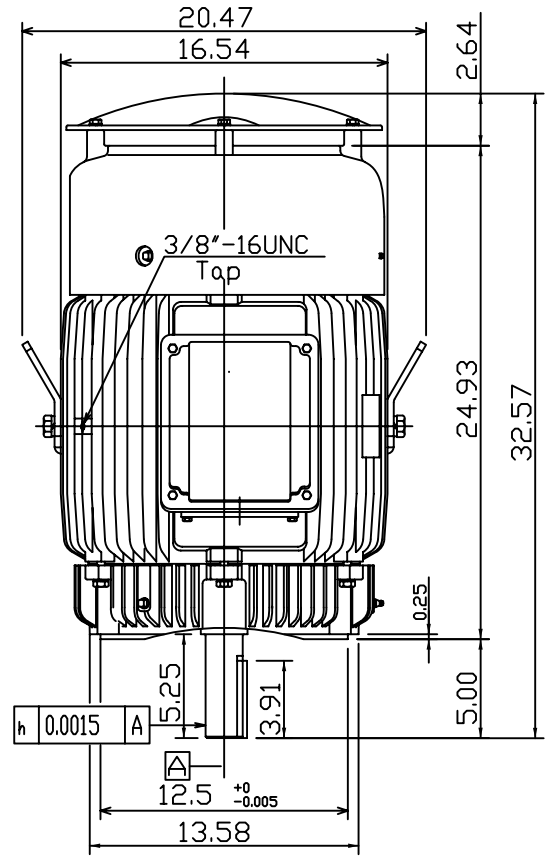

Note:
1. C/W Inpro/Seal In Both End Brackets.
2. Motor Vibration:15?

0	.	.
---	---	---

DWN.	???????	01 01 09
CHKD.	???????	01 02 09
APPD.	???????	01 02 09



DWG NO.
31057H416250