

DATE
Sept. 12, 2005
CAT. #: HH1002

OUTLINE DIMENSIONS
3-PHASE INDUCTION MOTOR

MOTOR TYPE:
AEHH
FRAME NO. 405TS

Pole	HP	kW	Hz	VOLT	Syn. Speed r/min(rpm)
2	100	75	60	460	3600

Ins	Rating	Dimension in	Approx Weight	Bearings
F	CONT.	inches	1144 lbs.	DE: 6313C3 NDE: 6313ZC35C

Totally Enclosed Fan Cooled Type, Squirrel-cage Rotor.

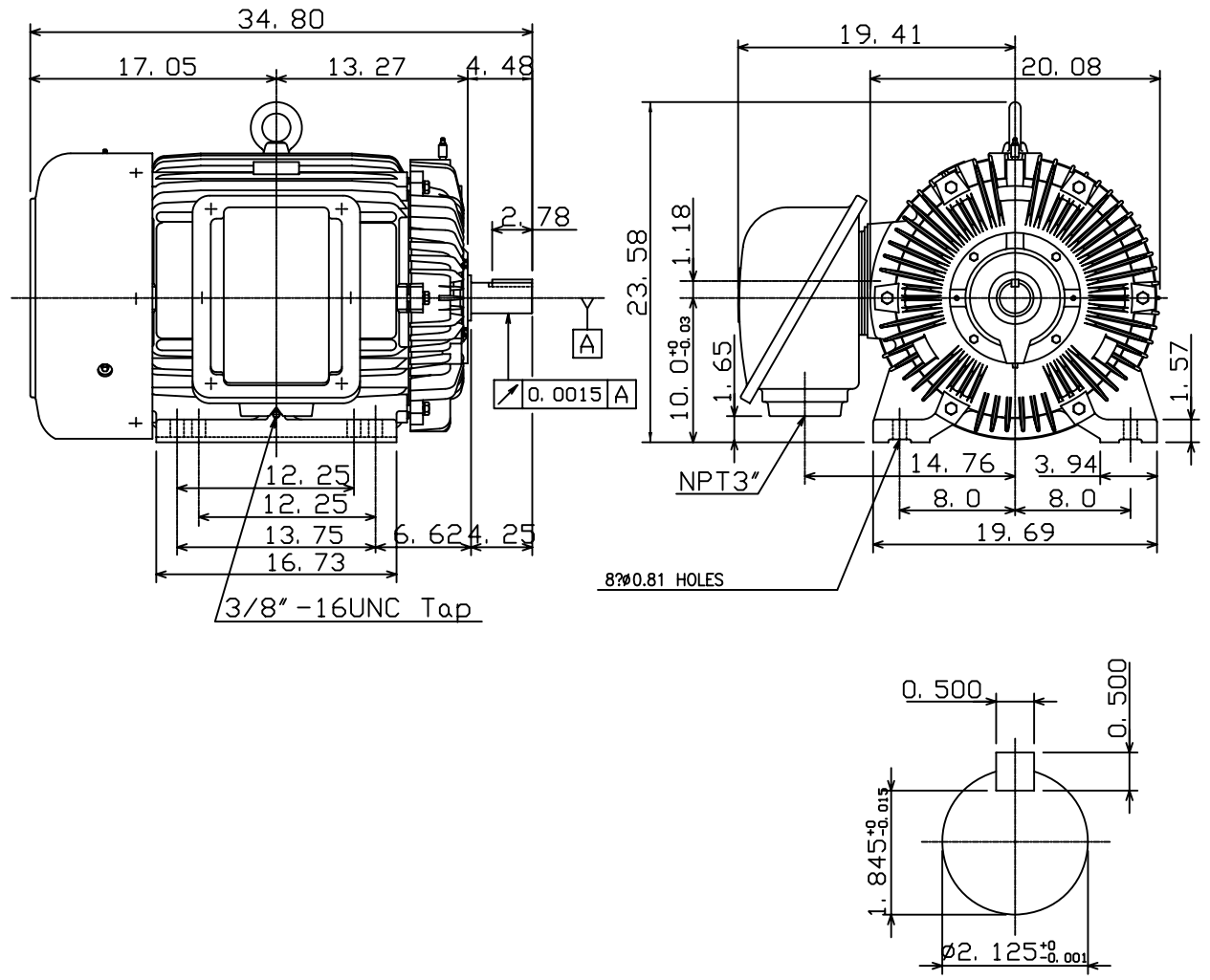

◇		
---	--	--

DWN.	K. L. KUD	01-18-05
CHKD.	C. H. KAD	02-02-05
APPD.	M. C. TSAI	02-02-05



DWG NO.
31049M634570