

SYM	REVISION	BY	DATE
A	REVISED & REDRAWN	BSK	8/2/95

SCALE: 2X

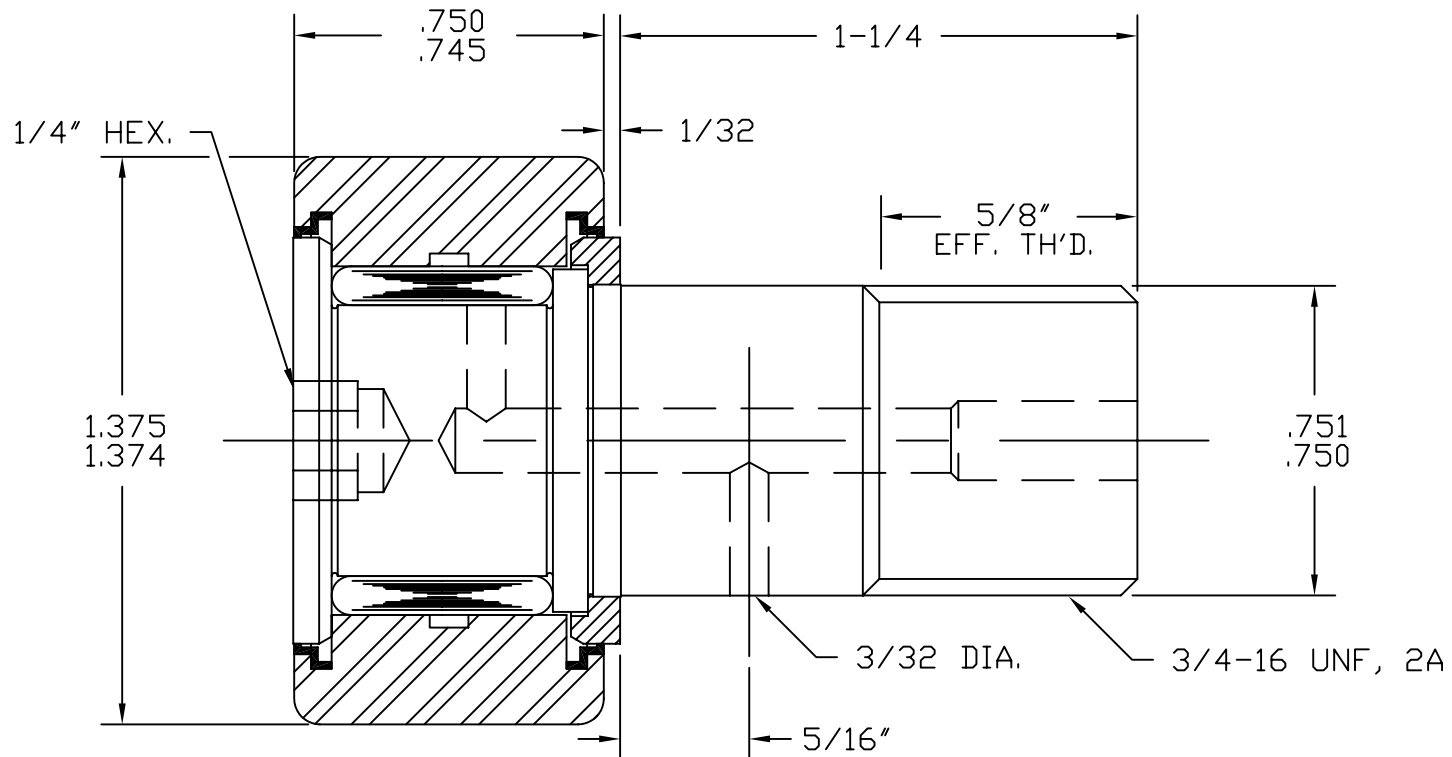

BASIC DYNAMIC CAPACITY - 3390
 MAX. ALLOWABLE LOAD - 4000

MAT'L: ST'D BEARING STEELS, SEALS - ACETAL.
 BEARING PACKED WITH GENERAL PURPOSE EP GREASE.
 RELUBE PROVISIONS WILL ACCEPT 3/16" DRIVE TYPE
 FITTINGS, PLUGS SUPPLIED FOR UNUSED HOLES.

TOLERANCES	
UNLESS OTHERWISE NOTED	
FRACTIONS: ±.010	ANGLES: ±.5
2 PLACE DECIMALS (.00): ±.005	
3 PLACE DECIMALS (.000): ±.002	



ACCURATE BUSHING CO. INC.
 Manufacturers of SMITH® Bearing Product
 443 NORTH AVENUE
 Garwood, NJ 07027

PART NAME	STANDARD CAM FOLLOWER		
PART NO.	HR-1-3/8-XB		
DRAWN BY	BSK	DATE	8/2/95
CHECKED BY		FILENAME	\HRASSYS\1-3-8-XB