

BALDOR® • RELIANCE 

Product Information Packet

JSL725A

2HP,3450RPM,1PH,60HZ,3528L,N

Part Detail							
Revision:	L	Status:	PRD/A	Change #:		Proprietary:	No
Type:	AC	Elec. Spec:	35WGL467	CD Diagram:	CD0203	Mfg Plant:	
Mech. Spec:	35E2011	Layout:	35LYE2011	Poles:	02	Created Date:	01-26-2016
Base:	N	Eff. Date:	08-15-2018	Leads:	4#14 A&J,1#18 B PH,1#12 #1TH		

Specs			
Catalog Number:	JSL725A	Inverter Code:	Not Inverter
Enclosure:	OPSB	KVA Code:	J
Frame:	56YZ	Lifting Lugs:	No Lifting Lugs
Frame Material:	Steel	Locked Bearing Indicator:	Locked Bearing
Output @ Frequency:	2.000 HP @ 60 HZ	Motor Lead Quantity/Wire Size:	4 @ 14 AWG, A&J
Synchronous Speed @ Frequency:	3600 RPM @ 60 HZ	Motor Lead Exit:	Terminal Panel
Voltage @ Frequency:	230.0 V @ 60 HZ	Motor Lead Termination:	None
	115.0 V @ 60 HZ	Motor Type:	3528L
XP Class and Group:	None	Mounting Arrangement:	F1
XP Division:	Not Applicable	Power Factor:	81
Agency Approvals:	CSA	Product Family:	General Purpose
	UR	Pulley End Bearing Type:	Ball
Auxillary Box:	No Auxillary Box	Pulley Face Code:	Pool Pump
Auxillary Box Lead Termination:	None	Pulley Shaft Indicator:	Ext Thread & Tapped Hole
Base Indicator:	No Mounting	Rodent Screen:	None
Bearing Grease Type:	Polyrex EM (-20F +300F)	RoHS Status:	ROHS COMPLIANT
Blower:	None	Shaft Extension Location:	Pulley End
Current @ Voltage:	11.000 A @ 230.0 V	Shaft Ground Indicator:	No Shaft Grounding

Product Information Packet: JSL725A - 2HP,3450RPM,1PH,60HZ,3528L,N

	13.300 A @ 208.0 V	Shaft Rotation:	Fixed Opposite Standard
	22.000 A @ 115.0 V	Shaft Slinger Indicator:	Shaft Slinger
Design Code:	L	Speed Code:	Single Speed
Drip Cover:	No Drip Cover	Motor Standards:	NEMA
Duty Rating:	CONT	Starting Method:	Direct on line
Electrically Isolated Bearing:	Not Electrically Isolated	Thermal Device - Bearing:	NONE (OLD)
Feedback Device:	NO FEEDBACK	Thermal Device - Winding:	None
Front Face Code:	Terminal Panel	Vibration Sensor Indicator:	No Vibration Sensor
Front Shaft Indicator:	None	Winding Thermal 1:	Automatic Thermal Overload
Heater Indicator:	No Heater	Winding Thermal 1 Location:	EP
Insulation Class:	B	Winding Thermal 2:	None

Nameplate NP1257L	
CAT.NO.	JSL725A
SPEC.	35E2011L467G1
HP	2
VOLTS	115/230
AMP	22/11
RPM	3450
FRAME	56YZ
SER.F.	1.20
NEMA-NOM-EFF	74
RATING	40C AMB-CONT
CC	
DE	6203
ENCL	OPSB
	SFA 25.2/12.6
	CODE J
	DES L
	CL B
	PF 81
	HZ 60
	PH 1
	USABLE AT 208V 13.3
	ODE 6203
	SN

Parts List		
Part Number	Description	Quantity
SA314708	SA 35E2011L467G1	1.000 EA
RA302192	RA 35E2011L467G1	1.000 EA
TPCRJ38CS	THERMAL 1PH 1.00 AUT 135C	1.000 EA
EC4645A03SP	ELEC CAP, 645-774 MFD, 125V, 1.81D X 3.	1.000 EA
11XT0832G06	8-32 X 3/8 TY 23 TAPPING	1.000 EA
WD1000B16	T&B CX70TN TERMINAL	1.000 EA
51XB1016A07	10-16 X 7/16 HXWSSLD SERTYB	1.000 EA
35EP3202B17	FREP OPEN 35L RESIL W/.50 NPT, .64 SHAF	1.000 EA
HW5100A03	WAVY WASHER (W1543-017)	1.000 EA
WD4100A90	CAPLUG BPF-5/8, FOR .61-.63 HOLE	1.000 EA
SP1033A01	INSULATOR MODEL 35 TERM PANEL	1.000 EA
51XW0832A07	8-32 X .44, TAPTITE II, HEX WSHR SLTD SE	3.000 EA
35CB4802A02SP	CAPACITOR COVER, STAMPED X	1.000 EA
51XB1016A05	10-16X5/16HX WA SL SR TYB (F/S)	2.000 EA
34EP3501A03	ENDPLATE, MACH POOL PUMP 17 FRAME-ASSY/K	1.000 EA
51XN1032A16	10-32 X 1.000 HX WS SL SR	2.000 EA
HA6647A03	ADAPTER, 34EP3501 TO 35 FRAME STATOR	1.000 EA
51XN1032A16	10-32 X 1.000 HX WS SL SR	4.000 EA
35AD2013	BAFFLE PLATE, STAMPED STEEL FOR 34EP2502	1.000 EA
HA2001A10	SPACER, .218 ID X .1.250 LG	4.000 EA
11XF0832A24	8.32X1.50HXWSHR HD,SL,TYF	4.000 EA
35CB4500SP	TERMINAL BOX LID STAMPED	1.000 EA
51XW0832A07	8-32 X .44, TAPTITE II, HEX WSHR SLTD SE	2.000 EA
HW4600B39SP	V-RING SLINGER 0.550 X 0.790 X .18 VITON	1.000 EA

Parts List (continued)		
Part Number	Description	Quantity
RM1010A12	.437 I.D. 1" VINYL CAP (SHORT) MOCAP	1.000 EA
85XU0407S04	4X1/4 U DRIVE PIN STAINLESS	2.000 EA
LB1009N	LABEL,ROTATION DIRECTION (ON ROLLS)	1.000 EA
MJ1000A02	GREASE, POLYREX EM EXXON (USe 4824-15A)	0.050 LB
MG1000G27	MED CHARCOAL METALLIC GREY 400-0096	0.017 GA
HA6015A02	THERMAL RETAINER (PLATED)	1.000 EA
NS2500A06	INSULATOR,AUTO THER PROT,W/PSA ON 1 SIDE	1.000 EA
51XW0832A07	8-32 X .44, TAPTITE II, HEX WSHR SLTD SE	2.000 EA
SP5066A01	35 TERM PANEL SWITCH W/E-BLK, 8-RED	1.000 EA
HA3100A27	THRUBOLT 10-32 X 11.875	4.000 EA
LB1118	LABEL,WARNING (ROLL LABEL)	1.000 EA
LC0546	CONNECTION LABEL	1.000 EA
NP1257L	ALUM UL CSA CC THERMAL REV MTG	1.000 EA
36PA1000	PKG GRP, PRINT PK1016A06	1.000 EA
PK3083T	STYROFOAM PACKING CRADLE	1.000 EA
PK3088	MICROFOAM, 8"X"8 PERF. SHEETS 5,400/RL	1.000 EA
MN416A01	TAG-INSTAL-MAINT no wire (1200/bx) 5/18	1.000 EA
PE-0000001	ZRTG PE ASSEMBLY	1.000 EA

AC Induction Motor Performance Data

Record # 54667 - Typical performance - not guaranteed values

Winding: 35WGL467-R001	Type: 3528L	Enclosure: OPEN
-------------------------------	--------------------	------------------------

Nameplate Data				115 V, 60 Hz: Low Voltage Connection	
Rated Output (HP)	2			Full Load Torque	3.05 LB-FT
Volts	115/230			Start Configuration	direct on line
Full Load Amps	22/11			Breakdown Torque	8.39 LB-FT
R.P.M.	3450			Pull-up Torque	4.22 LB-FT
Hz	60	Phase	1	Locked-rotor Torque	6.51 LB-FT
NEMA Design Code	L	KVA Code	J	Starting Current	130 A
Service Factor (S.F.)	1.2			No-load Current	11.8 A
NEMA Nom. Eff.	74	Power Factor	81	Line-line Res. @ 25°C	0.233 Ω A Ph 0.862 Ω B Ph
Rating - Duty	40C AMB-CONT			Temp. Rise @ Rated Load	47°C
S.F. Amps	25.2/12.6			Temp. Rise @ S.F. Load	56°C
				Locked-rotor Power Factor	76.7
				Rotor inertia	0.0774 LB-FT ²

Load Characteristics 115 V, 60 Hz, 2 HP

% of Rated Load	25	50	75	100	125	150	S.F.
Power Factor	49	65	76	81	85	86	84
Efficiency	50.8	67.3	71	74.8	73.8	71.5	74
Speed	3571	3551	3525	3501	3472	3434	3478
Line amperes	13	15.1	18.6	21.8	26	31.2	25.2

Performance Graph at 115V, 60Hz, 2.0HP Typical performance - Not guaranteed values

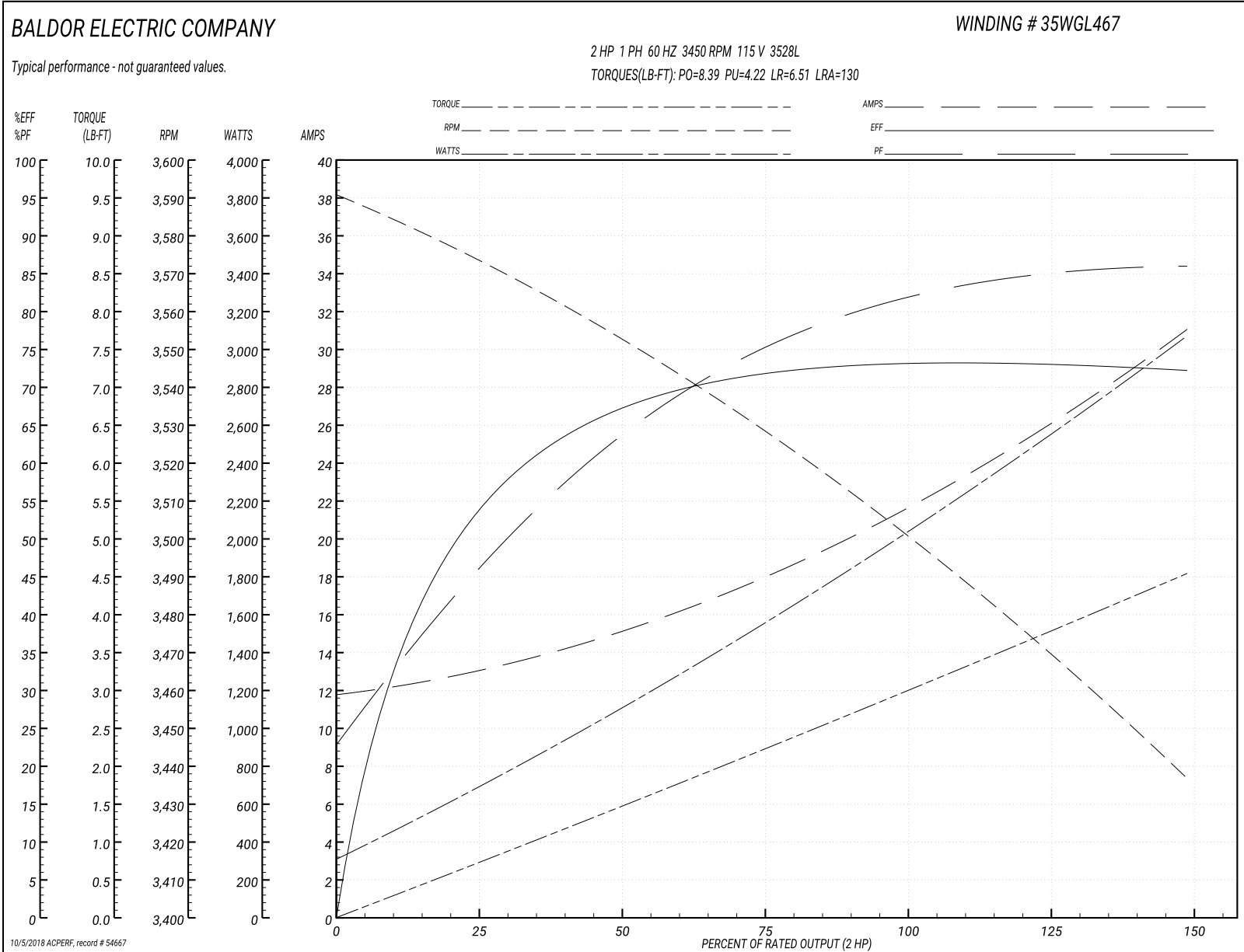

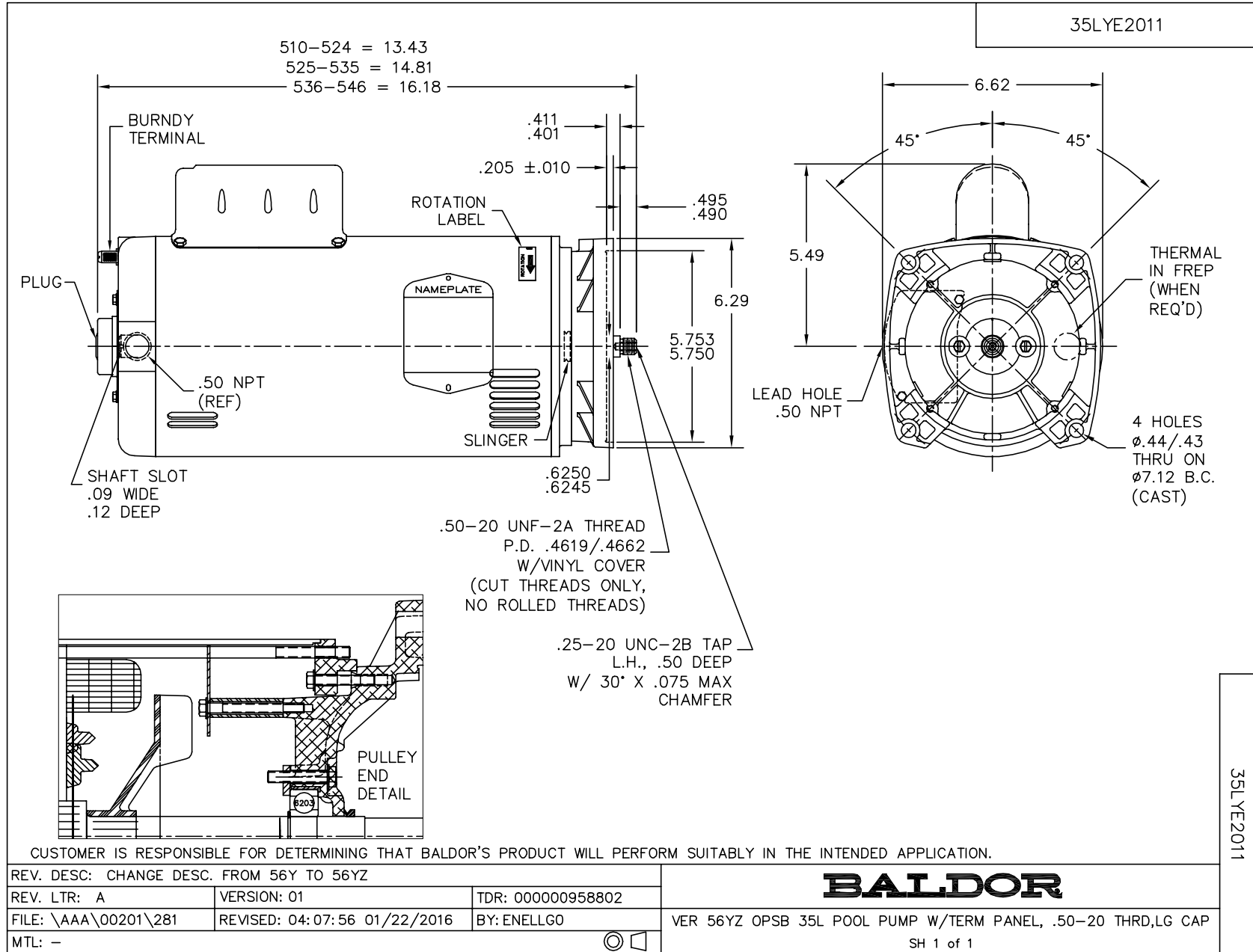

CD0203

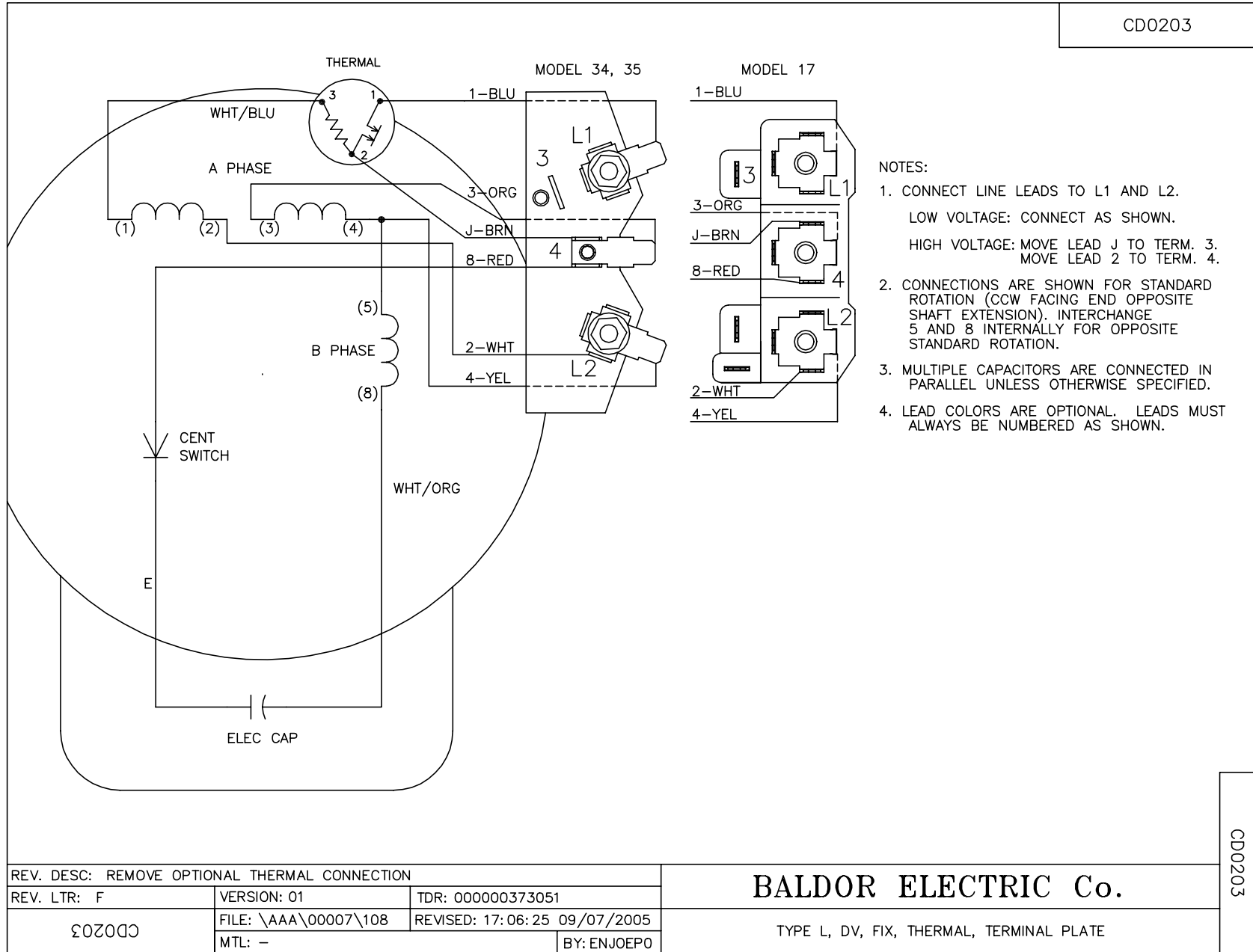

CD0203

REV. DESC: REMOVE OPTIONAL THERMAL CONNECTION			
REV. LTR: F	VERSION: 01	TDR: 00000373051	
CD0203	FILE: \AAA\00007\108	REVISED: 17:06:25 09/07/2005	
	MTL: -	BY: ENJOEPO	

BALDOR ELECTRIC Co.

TYPE L, DV, FIX, THERMAL, TERMINAL PLATE