

BALDOR® • RELIANCE 

Product Information Packet

LPL75

.75HP,3600RPM,1PH,60HZ,3524C,DENTAL LATH

Part Detail							
Revision:	BA	Status:	PRD/A	Change #:		Proprietary:	No
Type:	AC	Elec. Spec:	G8WG0011	CD Diagram:	CD0121	Mfg Plant:	
Mech. Spec:	G8-327	Layout:	G8LY0327	Poles:	02	Created Date:	08-08-2007
Base:	RG	Eff. Date:	07-20-2018	Leads:	4#18		

Specs			
Nameplate Output:	.75		
Product Style:	BUFFER		

Nameplate NP3352L

CAT.NO.	LPL75		
HP	.75	VOLTS	115/230
PHASE	1	AMPS	4.8/2.4
HZ	60	RPM	3600
SER.NO			
SPEC.	G8-327-11		
BLANK			

Parts List		
Part Number	Description	Quantity
SA037669	SA G8-327-11	1.000 EA
RA033694	RA G8-327-11	1.000 EA
OC3016F12SP	CYL OIL CAP 16MFD/370V	1.000 EA
G8BA3000	G8 & G10 BASE	1.000 EA
19XX2510A14	1/4-10 X 7/8 HEX HD PLASTITE SCREW	4.000 EA
HW1000A25	1/4 SAE FLAT WASHER (FS)	4.000 EA
HW1003A50	LOCKWASHER, 1/2", EXT. TOOTH ZINC PLATED	1.000 EA
51XN1032A04	10-32 X 0.25 HX WS SL SR	2.000 EA
XY1032A01	10/32 SQUARE NUT	2.000 EA
11XW1032G06	10-32 X .38, TAPTITE II, HEX WSHR SLTD U	1.000 EA
HW3001B01	BRASS CUP WASHER, FOR #10 SCREW	1.000 EA
LD5001A02	CORD & PLUG ASSY 18-3 SJT .33 DIA. 10 AM	1.000 EA
WD4102A01	SR-6L-1 HEYCO STRN RELIEF OR 23MPO6L10 M	1.000 EA
G8CB4500A02	G8-272 BASE COVER, STPD X PLATED	1.000 EA
51XW0832A07	8-32 X .44, TAPTITE II, HEX WSHR SLTD SE	2.000 EA
RM1005A01SP	BUMPER- #2089 (R-R CO)	4.000 EA
15XF1032A10	10-32X5/8 PIN HD PHL TY FSEE JT	4.000 EA
35EP3122F00	MASTER ODE, 203 BRG, #26 DRN	1.000 EA
HW5100A06	W2420-025 WVY WSHR (WB)	1.000 EA
HW5100A03	WAVY WASHER (W1543-017)	1.000 EA
HA1025A03	FELT WSH 2.1875 OD X 1.170 ID X .25 #321	1.000 EA
G8EP3900A01SP	ENDPLATE, MACH	1.000 EA
19XW2520A16	SCREW, 1/4-20X1 TAPTITE-II OR ROLOC 91	4.000 EA
HA3100A28	THRUBOLT 10-32 X 8.187	4.000 EA

Parts List (continued)		
Part Number	Description	Quantity
XY1032A02	10-32 HEX NUT DIRECTIONAL SERRATION	4.000 EA
SP9000SP	80600BJ A-H OR 1520237-2 TYCO;2PST,125/2	1.000 EA
HA6053A01ZP	CLAMP, CAPACITOR 2" DIA, WHITE ZINC PLAT	1.000 EA
MJ1000A02	GREASE, POLYREX EM EXXON (USe 4824-15A)	0.050 LB
HA1000A34	DR2463A .02 BRG GUARD B N	2.000 EA
85XU0407A04	#4-7 X 1/4 DRIVE PIN	2.000 EA
LB1009N	LABEL,ROTATION DIRECTION (ON ROLLS)	1.000 EA
LB1056	LABEL,TIME DELAY FUSE,(POLY-STIK-S)	1.000 EA
LB1091	LABEL, WARNING BUFFERS	1.000 EA
LC0279A01	1PH, DV, FIX, GRINDER, CONN FOR LV	1.000 EA
MG1000G18	PAINT, 189-905 SILVER HAMR	0.017 GA
LB1119N	WARNING LABEL	1.000 EA
NP3352L	ALUM NAMEPLATE - BALDOR BUFFER NO LOGOS	1.000 EA
36PA1001	PKG GRP, PRINT PK1017A06	1.000 EA
MN906	Baldor Buffer 6/13	1.000 EA
FE-0000001	ZRTG FE ASSEMBLY	1.000 EA

No performance data has been
assigned to this product.

G8LY0327

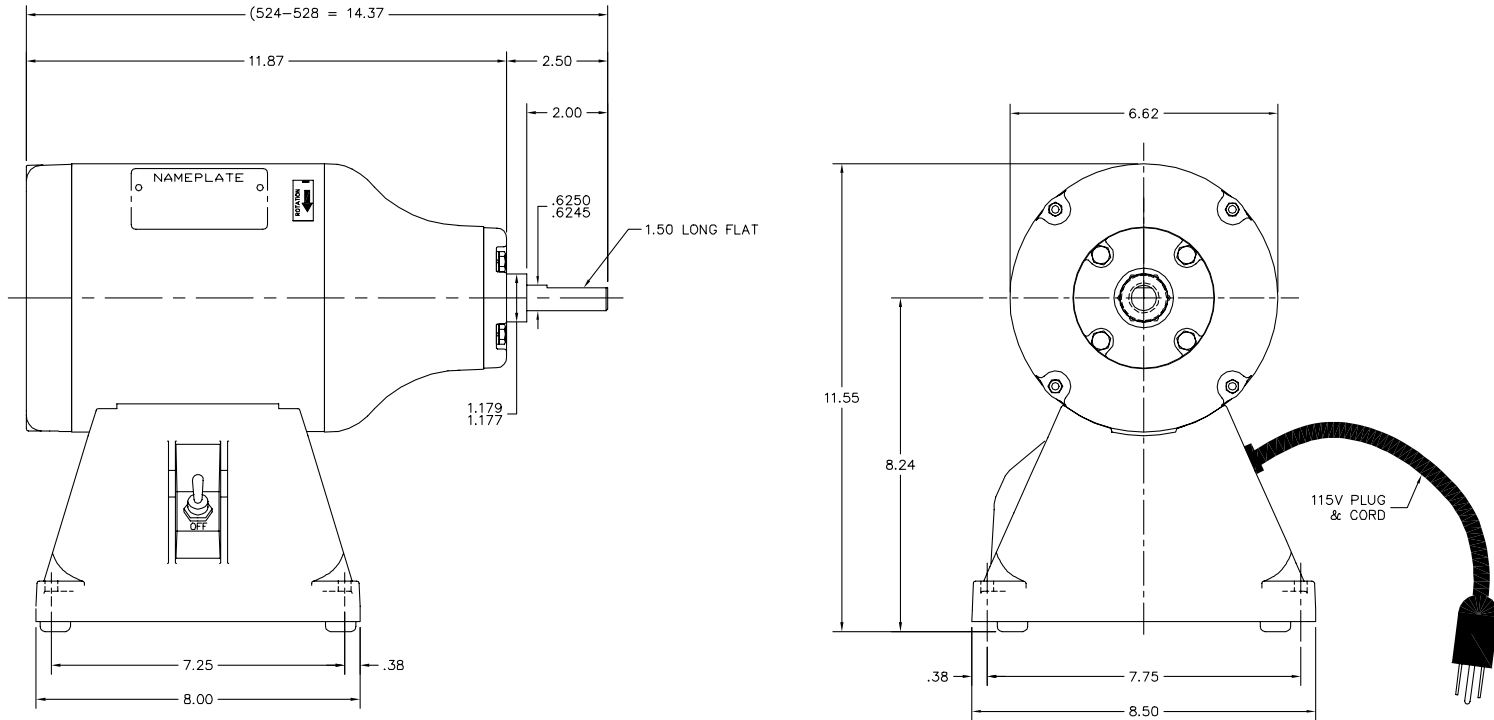

G8LY0327

CUSTOMER IS RESPONSIBLE FOR DETERMINING THAT BALDOR'S PRODUCT WILL PERFORM SUITABLY IN THE INTENDED APPLICATION.

REV. DESC: REPLACE ENDPLATES	VERSION: 02	TDR: 000001064040
REV. LTR: E	REVISED: 11:19:21 03/22/2018	BY: USJOBUR22
FILE: \AAA\00060\697		
MTL: -		

BALDOR - RELIANCE[®]
 B/SPL LAYOUT, (524C) 8" DENTAL LATHE
 SH 1 of 1

CD0121

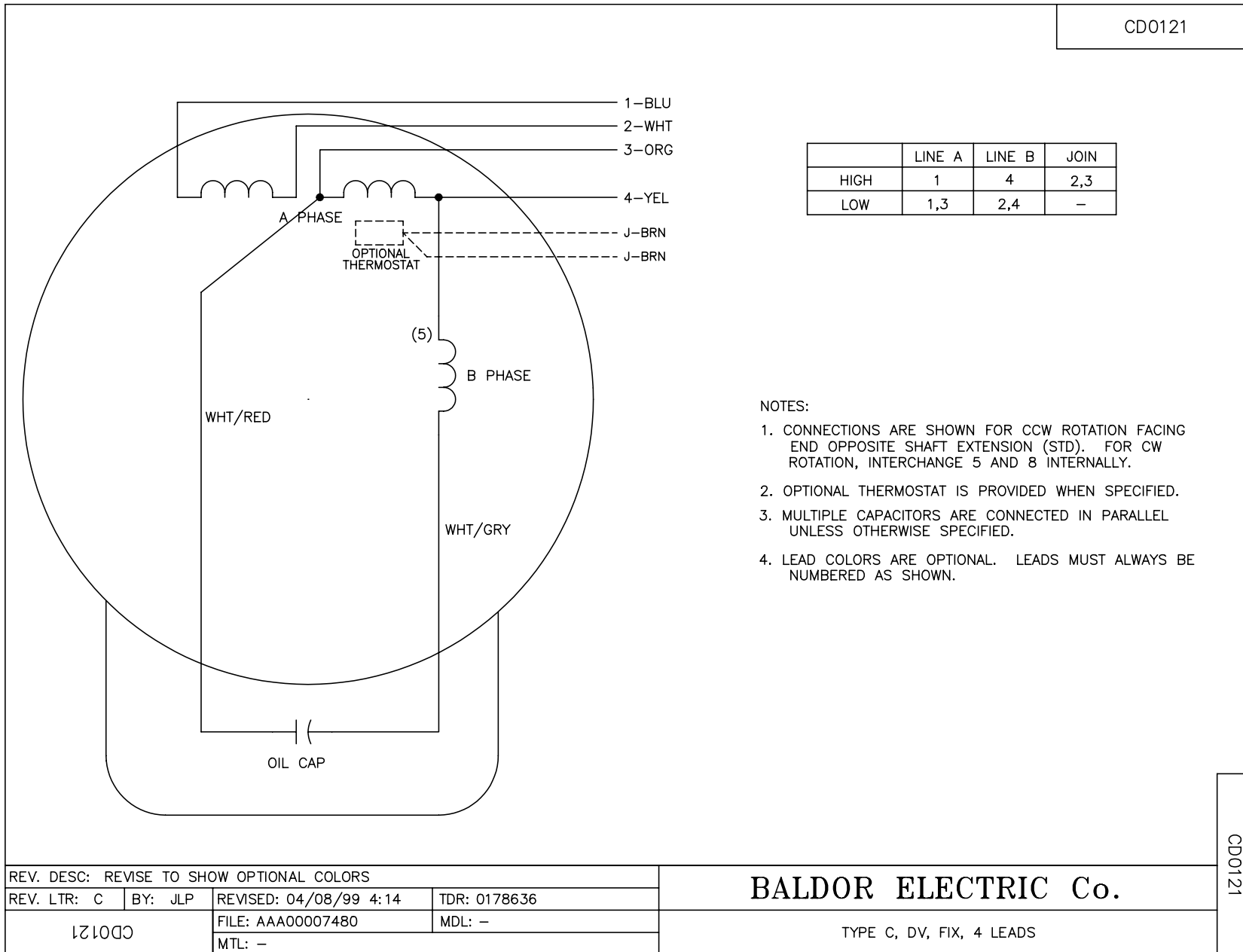

REV. DESC: REVISE TO SHOW OPTIONAL COLORS			
REV. LTR: C	BY: JLP	REVISED: 04/08/99 4:14	TDR: 0178636
CD0121		FILE: AAA00007480	MDL: -
		MTL: -	

BALDOR ELECTRIC Co.

TYPE C, DV, FIX, 4 LEADS

CD0121