

CAUTION!  
CONDUIT BOX MOUNTING SCREWS AND LEADS  
ARE AT 3:00 O'CLOCK FACING LEAD END

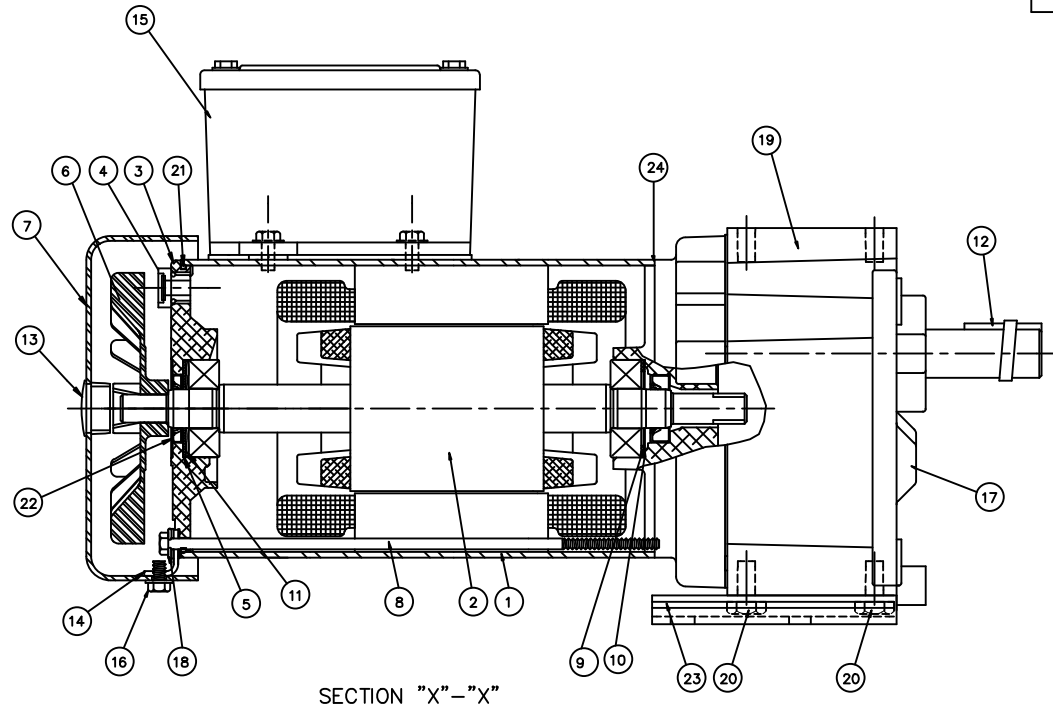
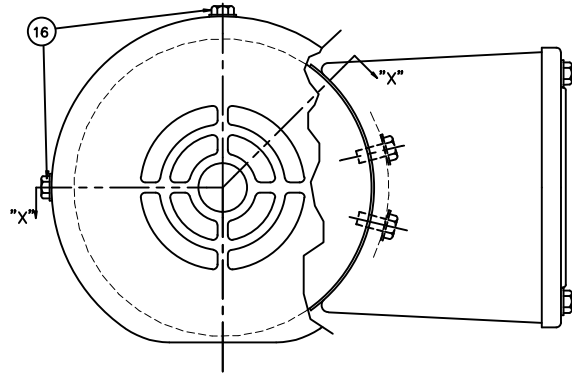

24	GASKET ELIMINATOR
23	BASE
22	SHAFT SEAL
21	O-RING
20	TFS 1/4-20 X .50 HEX SST
19	GEARBOX ASSEMBLY
18	SEALING WASHER
17	PIPE PLUG
16	TFS #8-32 X .25 HEX HEAD W/WASHER SST
15	CONDUIT BOX ASSEMBLY
14	BRACKET
13	HOLE PLUG
12	KEY 3/16 X 3/16 X 1.00 #303 S.S.
11	LOAD SPRING
10	SHIM WASHER .015
9	SHIM WASHER .03
8	#6-32 T-BOLT SST
7	FAN SHROUD
6	FAN
5	WASHER COVER W/ HOLE
4	BREATHER PLUG ASSEMBLY
3	ENDBELL MACHINED
2	ROTOR/SHAFT ASSEMBLY
1	FRAME/STATOR ASSEMBLY
ITEM	DESCRIPTION

		TOLERANCES UNLESS SPECIFIED		DRAWN SRS 10/30/08	
		DEC.	INCHES	CHK	
		.X	±.1	APPD	
		.XX	±.01	TITLE GENERAL ASSEMBLY - P240	
		.XXX	±.005	SCALE 5=8	
		.XXXX	±.0005	REF M1041173	
A	REMOVE WASHER 006682.01 PER ISAAC 10-4335	LST	10/4/10	FMF M1145145	
NO.	REVISION	BY & DATE	CHK	ANG	±1/2'
THIS DRAWING IN DESIGN AND DETAIL IS OUR PROPERTY AND MUST NOT BE USED EXCEPT IN CONNECTION WITH OUR WORK ALL RIGHTS OF DESIGN AND INVENTION ARE RESERVED THIS IS AN ELECTRONICALLY GENERATED DOCUMENT - DO NOT SCALE THIS PRINT			RFP	FINISH	PREV
			CAD FILE	M1041312	SIZE B
			DRAWING NO.	M1041312	REV. A