

(1) 1/2-14 NPT  
CONDUIT HOLE  
(PLUGGED)

.187 SQ KEY BY 1.00 LG

CONNECTION DECAL  
UNDER COVER

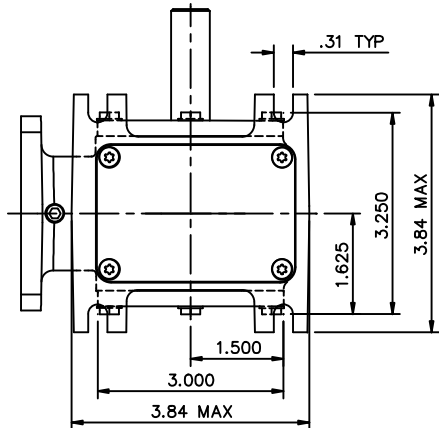

VIEW "Z-Z"

CATALOG NUMBER	SPEED RANGE RPM	FULL LOAD TORQUE LB.-IN.	INPUT HP	OVERHUNG LOAD LBS.	GEARMOTOR TYPE & FRAME	RATIO TO 1
M1145147.00	172	105	3/8	235	13F10-38F	10

- NOTES:  
 1) O-RINGS BETWEEN FRAME AND ENDBELLS.  
 2) GASKETS THROUGHOUT.

		TOLERANCES UNLESS SPECIFIED		LEESON	ELECTRIC MOTORS GEARMOTORS AND DRIVES	DRAWN			
		DEC.	INCHES			SRS 12/16/08			
		.X	±.1	TITLE	OUTLINE DRAWING R13 SERIES - 38 FRAME WASHGUARD	CHK			
		.XX	±.03			APPD			
		.XXX	±.005			SCALE 1=2			
01	ADDED LOCATION OF 1/2-14 NPT ISAAC 10-4079	GWS	6/14/11	.XXX	±.0005	MAT'L	REF M1030422.00		
NO.	REVISION	BY & DATE	CHK	ANG	±1/2"	FINISH	PREV		
THIS DRAWING IN DESIGN AND DETAIL IS OUR PROPERTY AND MUST NOT BE USED EXCEPT IN CONNECTION WITH OUR WORK ALL RIGHTS OF DESIGN AND INVENTION ARE RESERVED THIS IS AN ELECTRONICALLY GENERATED DOCUMENT - DO NOT SCALE THIS PRINT				RFP	CAD FILE	OLM1145147	SIZE	DRAWING NO.	REV.
				DIST		B	OLM1145147	01	