

DATE  
APRIL 25, 2011

OUTLINE DIMENSIONS  
3-PHASE INDUCTION MOTOR

MOTOR TYPE:  
AEHH8P-CF  
FRAME NO. 284TSC

CAT. #: NP0252C

Pole	HP	kW	Hz	VOLT	Syn.Speed r/min(rpm)
2	25	18.7	50	190/380	3000

Ins	Rating	Dimension in	Approx Weight	Bearings
F	CONT.	inch	408 lbs.	DE: 6211C3 NDE: 6211C3

Totally Enclosed Fan Cooled Type, Squirrel-cage Rotor.

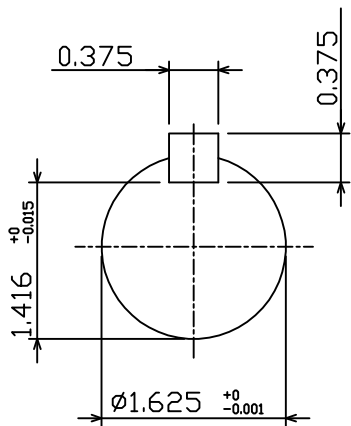
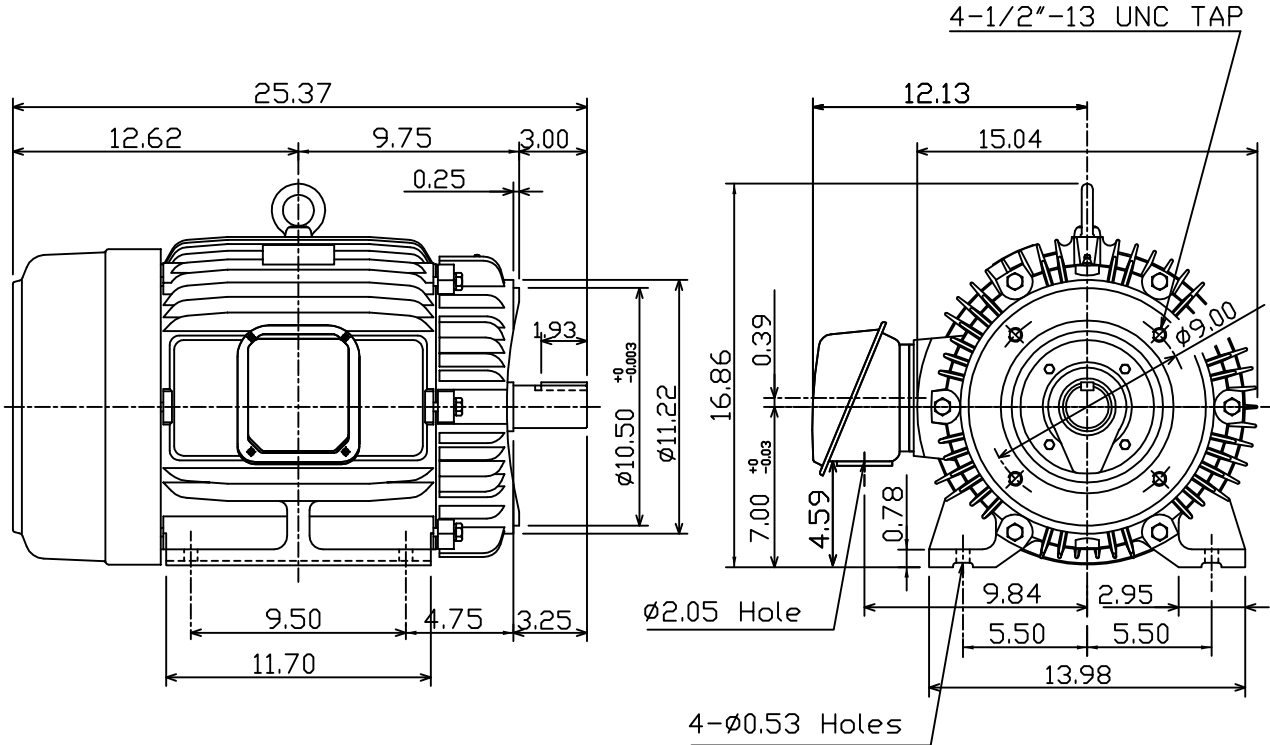

DWN.	K.L.KUD	04 -21 11
CHKD.	K.L.KUD	04 -21 11
APPD.	M.C.TSAI	04 -21 11

TEC   Westinghouse

DWG NO.  
31049J350180