

TYPE	OUTPUT		POLE	TIME RATING	VOLTAGE V	Hz	SYN SPEED R.P.M
	HP.	KW.					
AEHH8P	100	74.6	6	CONT.	190/380	50	1000

TOTALLY ENCLOSED FAN-COOLED TYPE, SQUIRREL-CAGE ROTOR

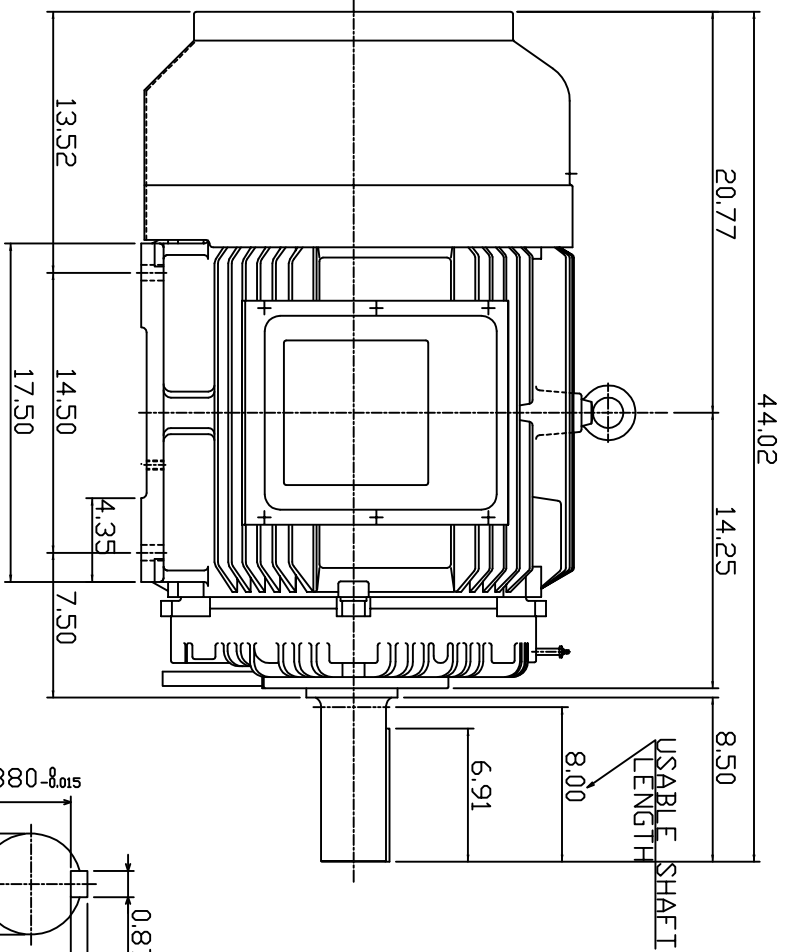
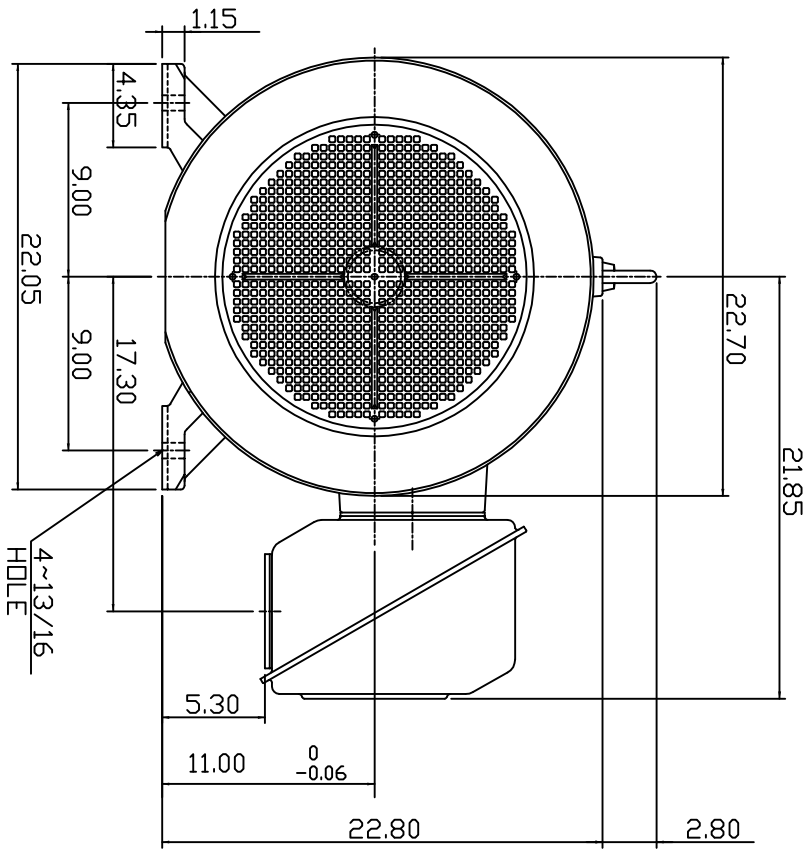

SHAFT END
[ENLARGED VIEW]

Ø3.375-8.001



- NOTE:
1. DIMENSIONS IN INCHES
 2. FRAME SIZE 444T
 3. F CLASS INSULATION, S.F. 1.0
 4. FOR DIRECT FLEXIBLE COUPLING
 5. BEARING NO.: DRIVE END: 6318C3
OPP. DRIVE END: 6316C3
 6. ENCLOSURE: IP44
 7. APPRDX. WEIGHT: 1580 LBS

DWN.	SLEE	JAN. 26 '2011
CHKD.	SLEE	JAN. 26 '2011
APPD.	H.LIU	JAN. 26 '2011

DATE	FEB. 11, 2011	OUTLINE DIMENSIONS
CATALOG #	NP1006	
3-PHASE INDUCTION MOTOR		



DWG NO. 3A049DWB10464-25
REV: 00

6 5 4 3 2 1