

TYPE	OUTPUT		POLE	TIME RATING	VOLTAGE V	Hz	SYN SPEED RPM
	HP.	KW.					
AEHH8P	100	74.6	6	CONT.	230/460	60	1200

TOTALLY ENCLOSED FAN-COOLED TYPE, SQUIRREL-CAGE ROTOR

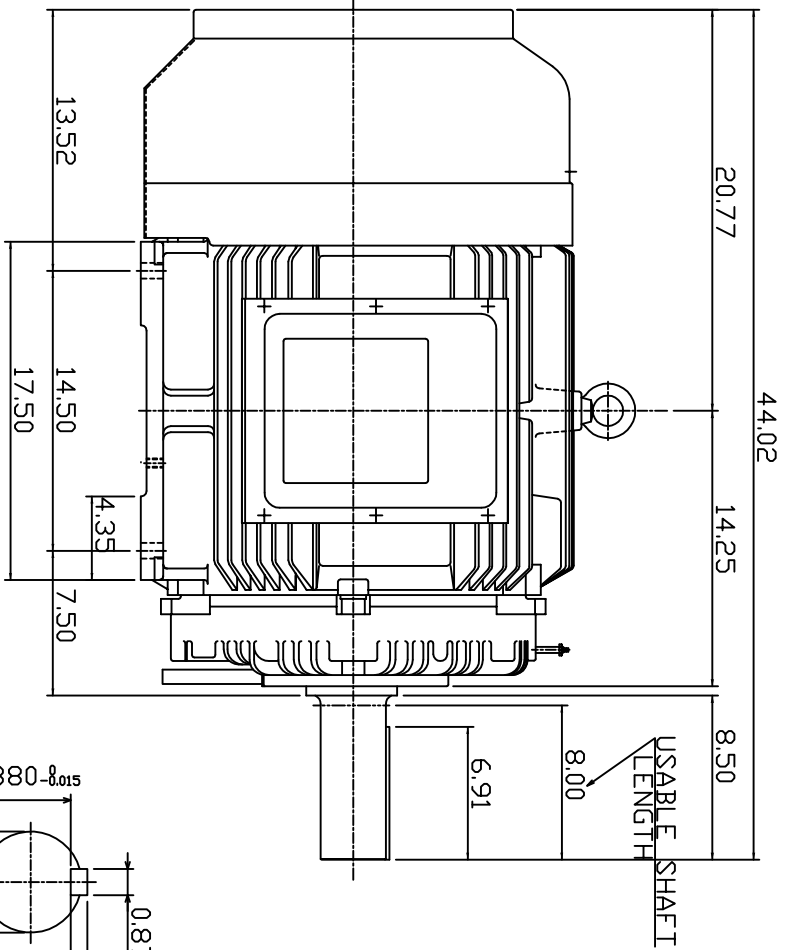
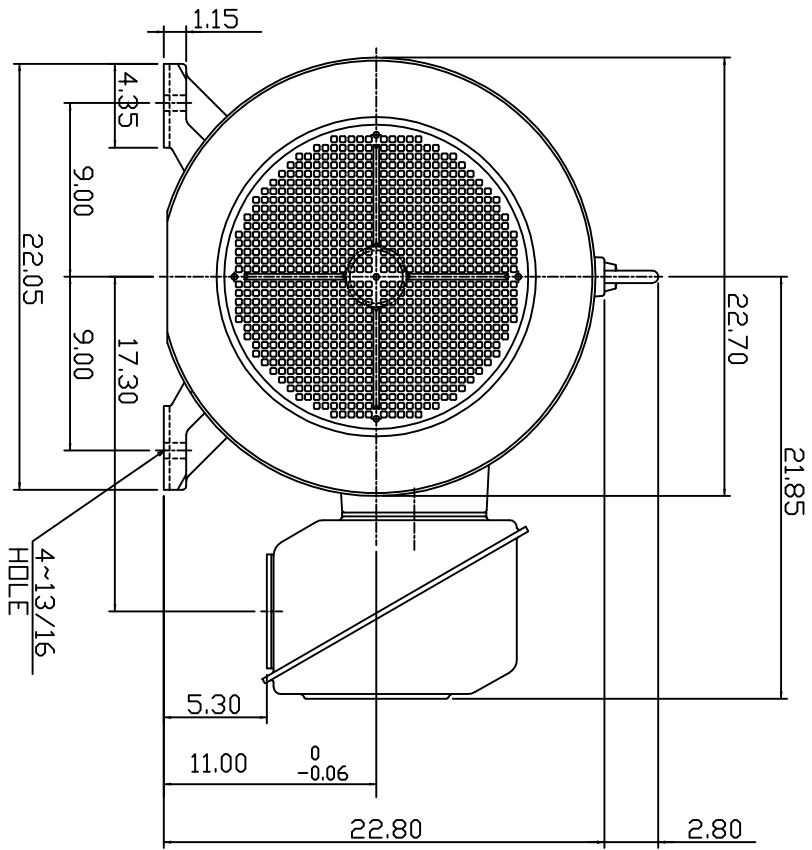

SHAFT END  
[ENLARGED VIEW]

NOTE:

1. DIMENSIONS IN INCHES
2. FRAME SIZE 444T
3. F CLASS INSULATION, S.F. 1.15
4. FOR DIRECT FLEXIBLE COUPLING
5. BEARING NO.: DRIVE END: 6318C3  
OPP. DRIVE END: 6316C3
6. ENCLOSURE: IP44
7. APPRDX. WEIGHT: 1580 LBS

DWN.	SLEE	JAN. 26 2011
CHKD.	SLEE	JAN. 26 2011
APPD.	H.LIU	JAN. 26 2011

DATE  
FEB. 11, 2011  
CATALOG #  
NP1006

OUTLINE DIMENSIONS  
3-PHASE INDUCTION MOTOR



DWG NO. 3A049DWB10464-25  
REV: 00

6 5 4 3 2 1