

TYPE	OUTPUT		POLE	TIME RATING	VOLTAGE	Hz	SYN SPEED
	HP.	KW.					
AEHH8P	150	111.9	2	CONT.	460	60	3600

TOTALLY ENCLOSED FAN-COOLED TYPE, SQUIRREL-CAGE ROTOR

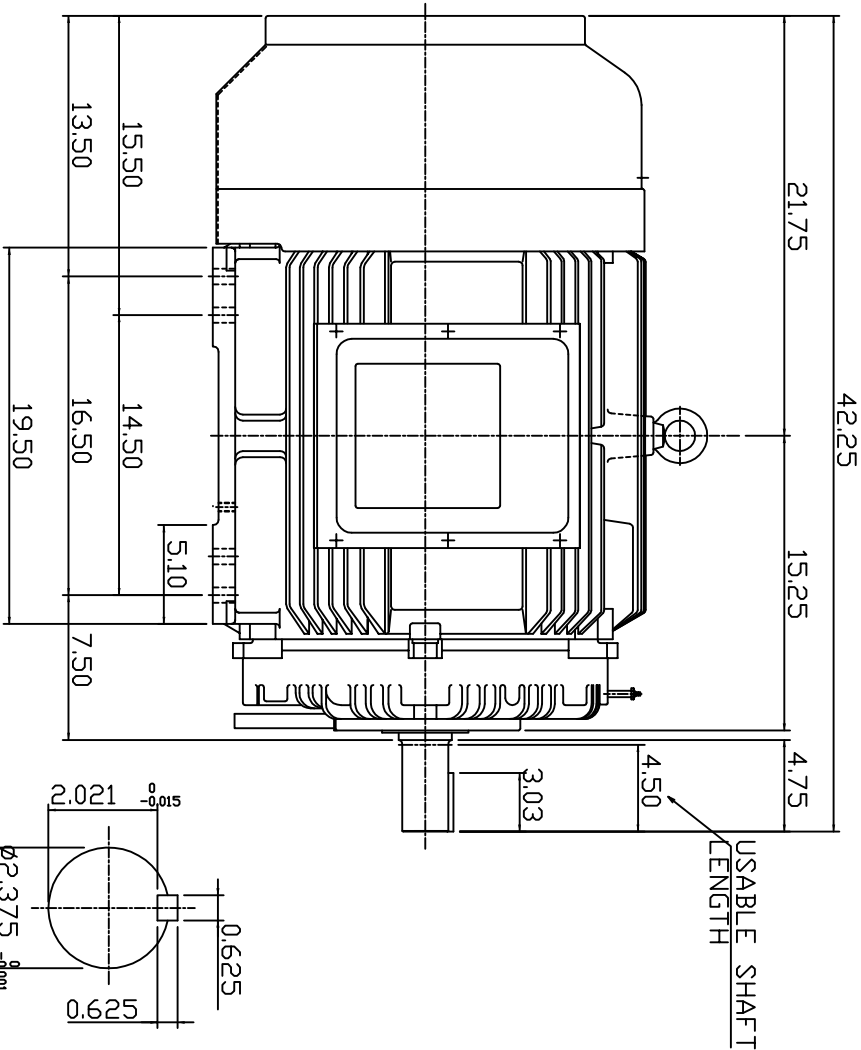
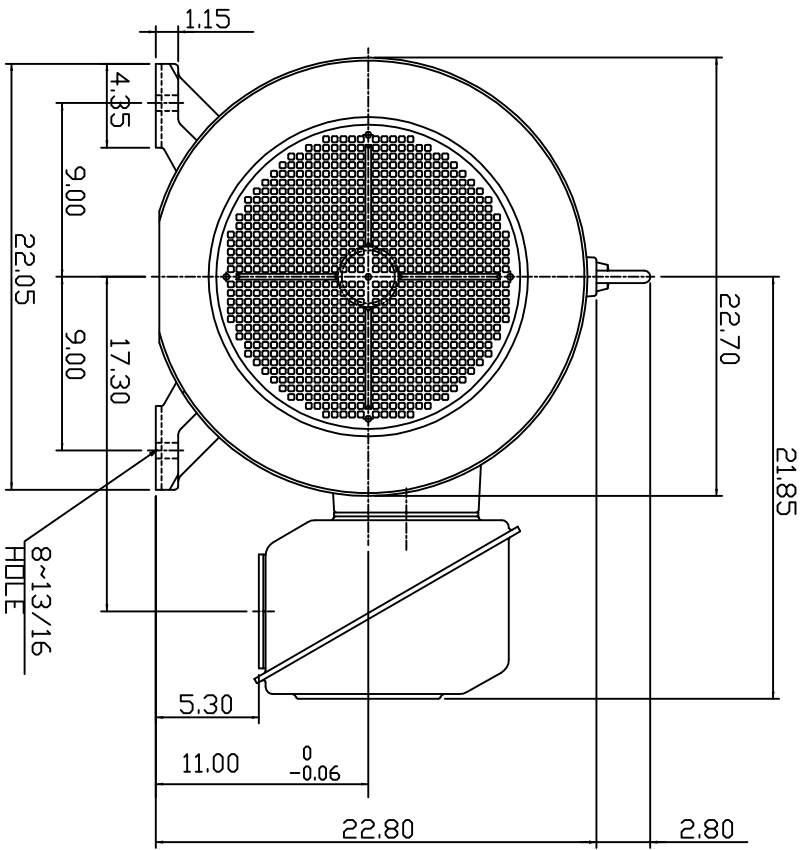

SHAFT END
[ENLARGED VIEW]

- NOTE:
1. DIMENSIONS IN INCHES
 2. FRAME SIZE 445TS
 3. F CLASS INSULATION, S.F. 1.15
 4. FOR DIRECT FLEXIBLE COUPLING
 5. BEARING NO.: DRIVE END: 6314C3
OPP. DRIVE END: 6314C3
 6. ENCLOSURE: IP44
 7. APPRDX. WEIGHT: 1600 LBS

DWN.	SLEE	JAN. 26 2011
CHKD.	SLEE	JAN. 26 2011
APPD.	H.LIU	JAN. 26 2011

DATE	OUTLINE DIMENSIONS
FEB. 11, 2011	3-PHASE INDUCTION MOTOR
CATALOG #:	
NP1502	



DWG NO. 3A049DWB10464-22
REV: 00

6 5 4 3 2 1