

REVISION HISTORY			
REV	DESCRIPTION	BY	DATE
A	ECO#: HFW161018-02	VD	02/06/2017

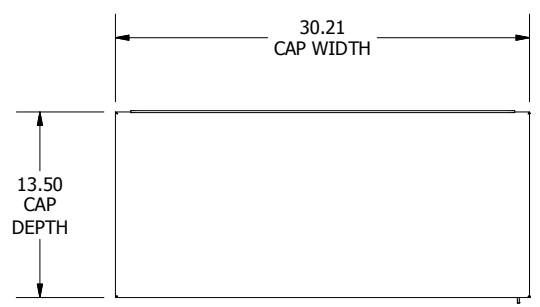

TOP VIEW

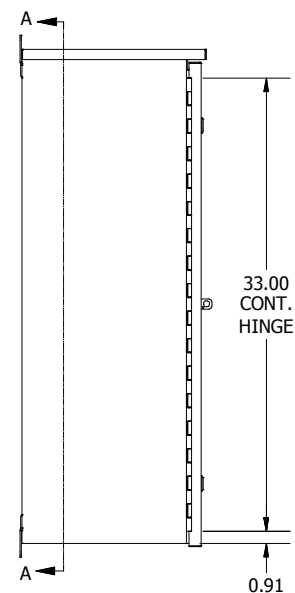
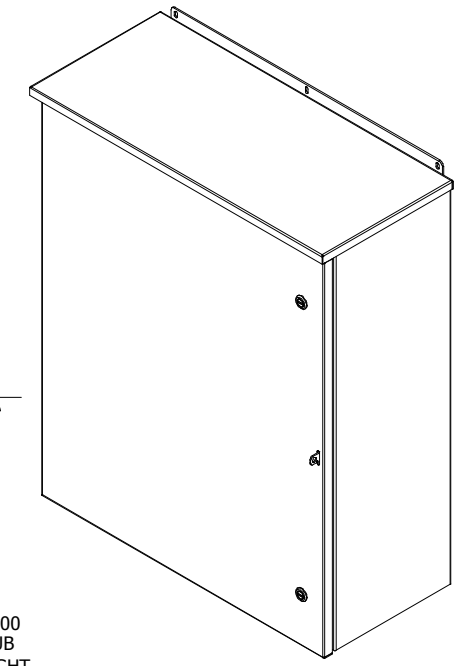

LEFT SIDE VIEW

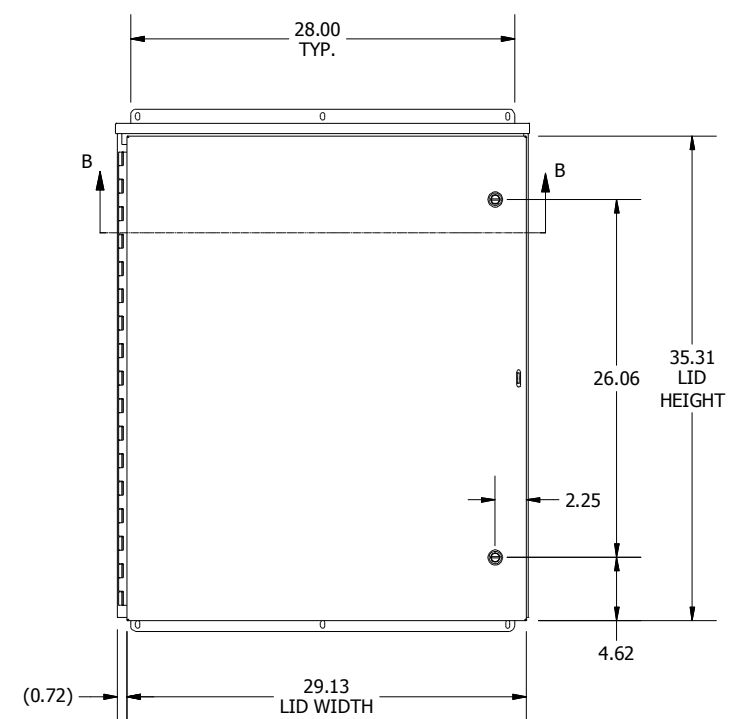

FRONT VIEW

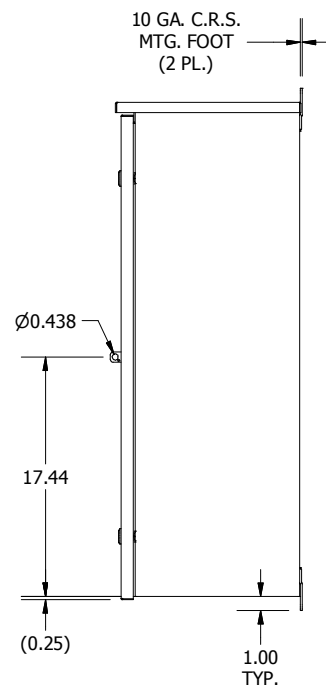

RIGHT SIDE VIEW

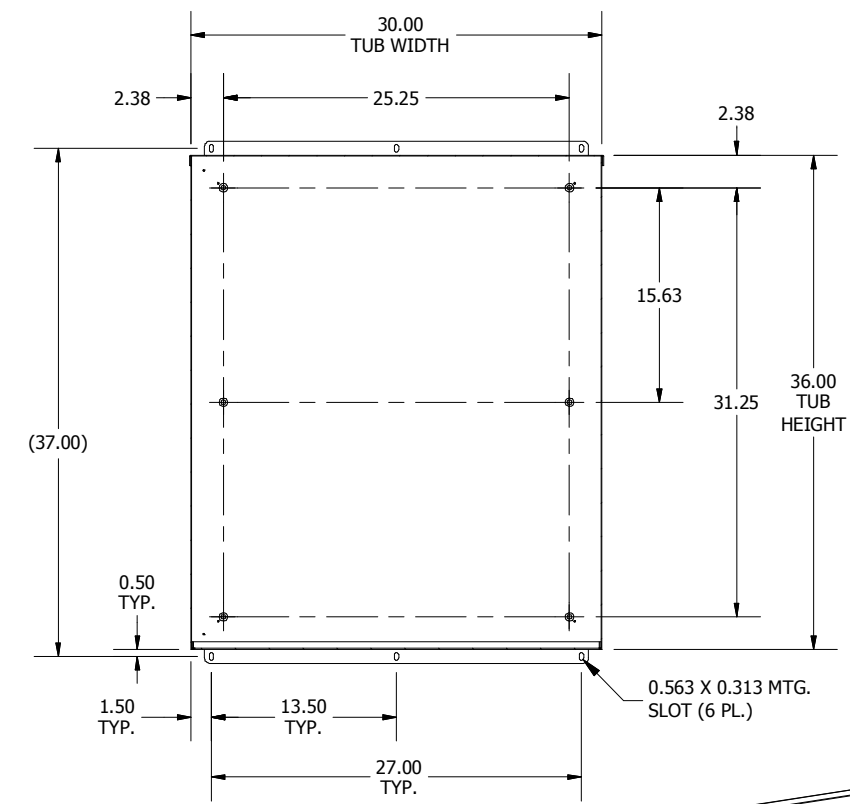

**SECTION A-A
(INSIDE BACK OF ENCL.)**

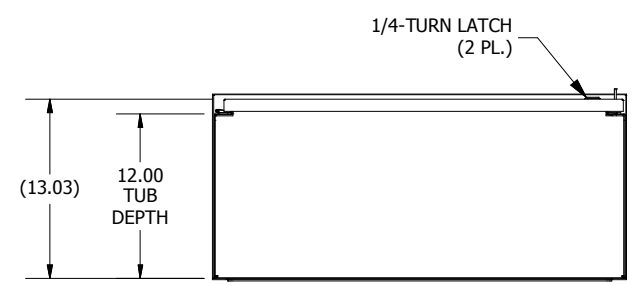
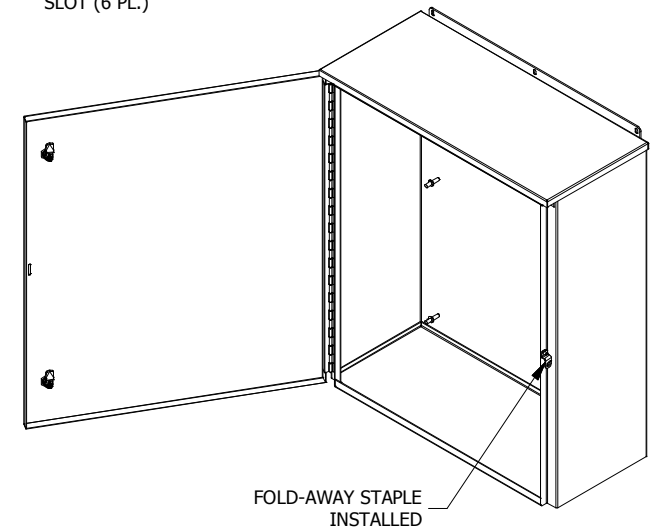

BOTTOM VIEW

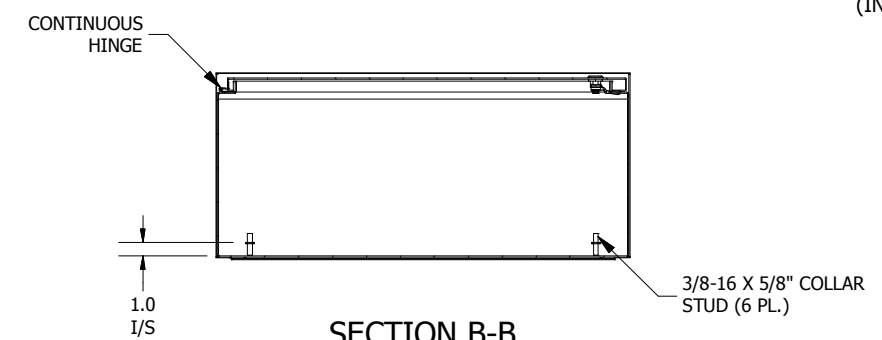

**SECTION B-B
(INSIDE TOP OF ENCL.)**

- NOTES:**
1. ALL DIMENSIONS ARE FROM OUTSIDE UNLESS OTHERWISE NOTED.
 2. ENCLOSURE IS FABRICATED FROM 14 GA. CARBON STEEL.
 3. COLLAR STUDS ARE PROVIDED FOR MOUNTING OPTIONAL SUB PANEL.
 4. ENCLOSURE IS WELDED TOGETHER.
 5. FINISH: ANSI-61 GRAY TEXTURE POLYESTER POWDER (INTERIOR/EXTERIOR).
 6. ENCLOSURE IS RATED UL TYPE 3R.

DIMENSIONS ARE IN INCHES (MM). TOLERANCES UNLESS OTHERWISE SPECIFIED ARE AS FOLLOWS:
 .X = ±.06 (1.6)
 .XX = ±.031 (.8)
 .XXX = ±.016 (.25)
 Ø = ±.005
 ANGLE TOL ±1'

HUBBELL **WIEGMANN**
 FREEBURG, ILLINOIS, USA

—NOTICE— THIS DRAWING IS THE PROPERTY OF WIEGMANN, A DIVISION OF HUBBELL INCORPORATED. IT IS LOANED TO YOU AND MUST NOT BE USED IN ANY WAY DETRIMENTAL TO THE INTEREST OF WIEGMANN.

PART NUMBER: RHC363012	MATERIAL: SEE NOTE	SCALE: NONE	CHK'D DATE: 7/10/2014
DESCRIPTION: RHC, NEMA 3R ENCL., CS, 36X30X12		DRAWN BY: PS	CREATED ON: 7/10/2014
		CHK'D BY: VR	DWG. NO. HWD RHC363012_1
		SHEET 1 OF 9	REV. A

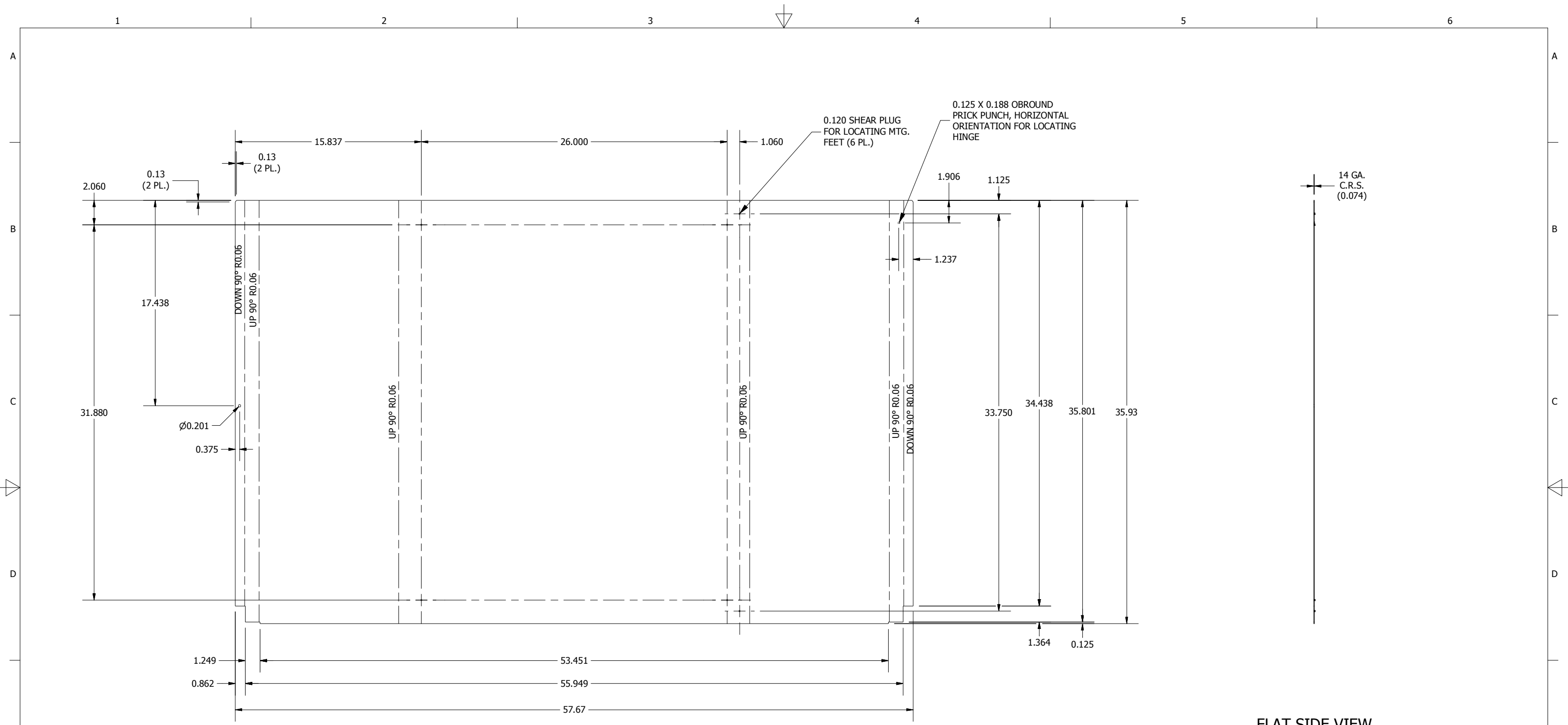

BLR FLAT PATTERN VIEW

FLAT SIDE VIEW

DIMENSIONS ARE IN INCHES (MM). TOLERANCES UNLESS OTHERWISE SPECIFIED ARE AS FOLLOWS: .X = ±.06 (1.6) .XX = ±.031 (.8) .XXX = ±.016 (.25) Ø = ±.005 ANGLE TOL ±1°	 WIEGMANN FREEBURG, ILLINOIS, USA	PART NUMBER: RHC363012BLR	MATERIAL: SEE NOTE	SCALE: NONE DRAWN BY: PS CHK'D BY: VR	CHK'D DATE: 7/10/2014 CREATED ON: 7/10/2014	DWG. NO. HWRHC363012_2.1	REV. A
		DESCRIPTION: RHC, BLR, MEDIUM, CS, 36X30X12			SHEET 2 OF 9		
		-NOTICE- THIS DRAWING IS THE PROPERTY OF WIEGMANN, A DIVISION OF HUBBELL INCORPORATED. IT IS LOANED TO YOU AND MUST NOT BE USED IN ANY WAY DETRIMENTAL TO THE INTEREST OF WIEGMANN.			SHEET 6 OF 9		

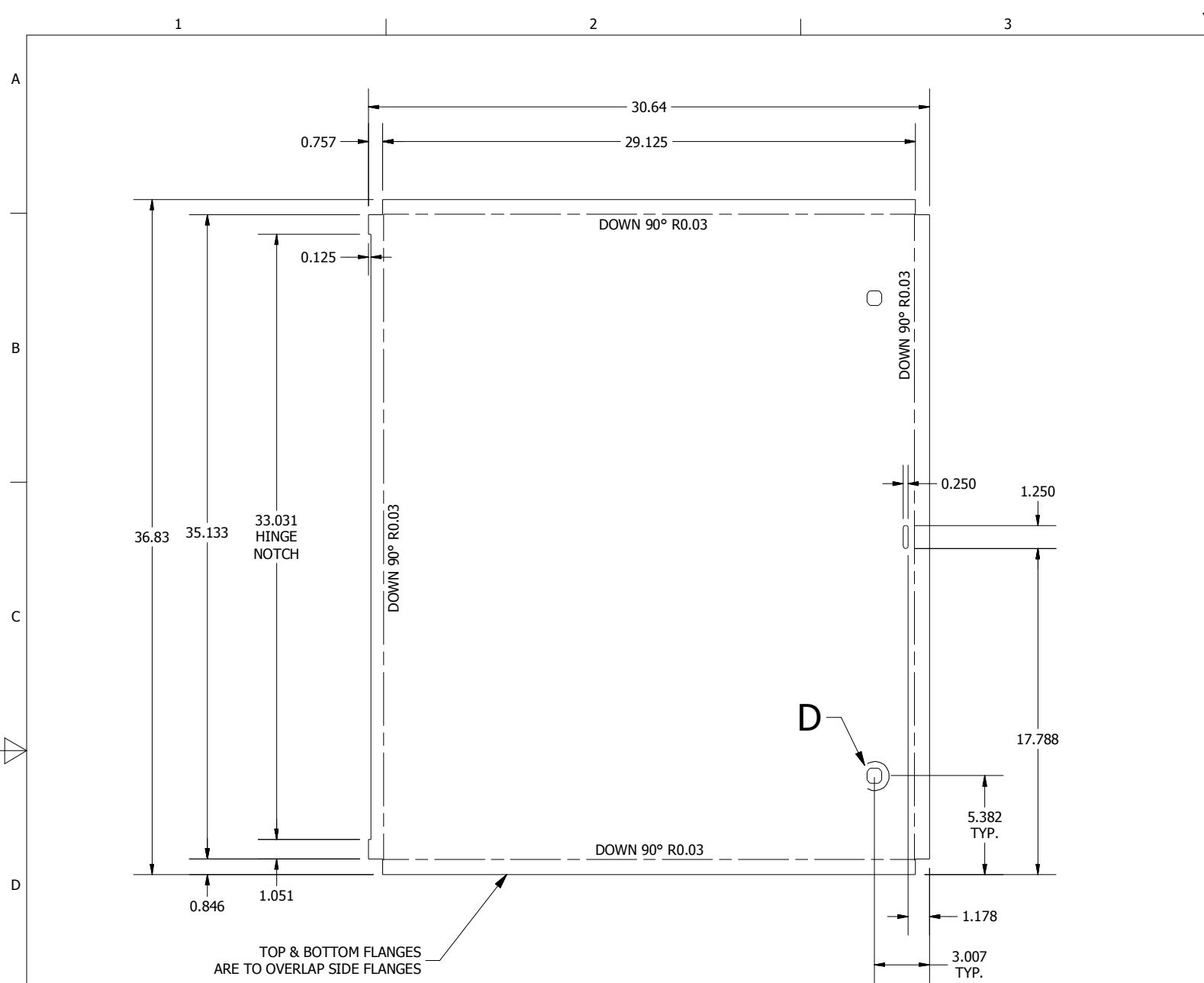

LID FLAT PATTERN VIEW

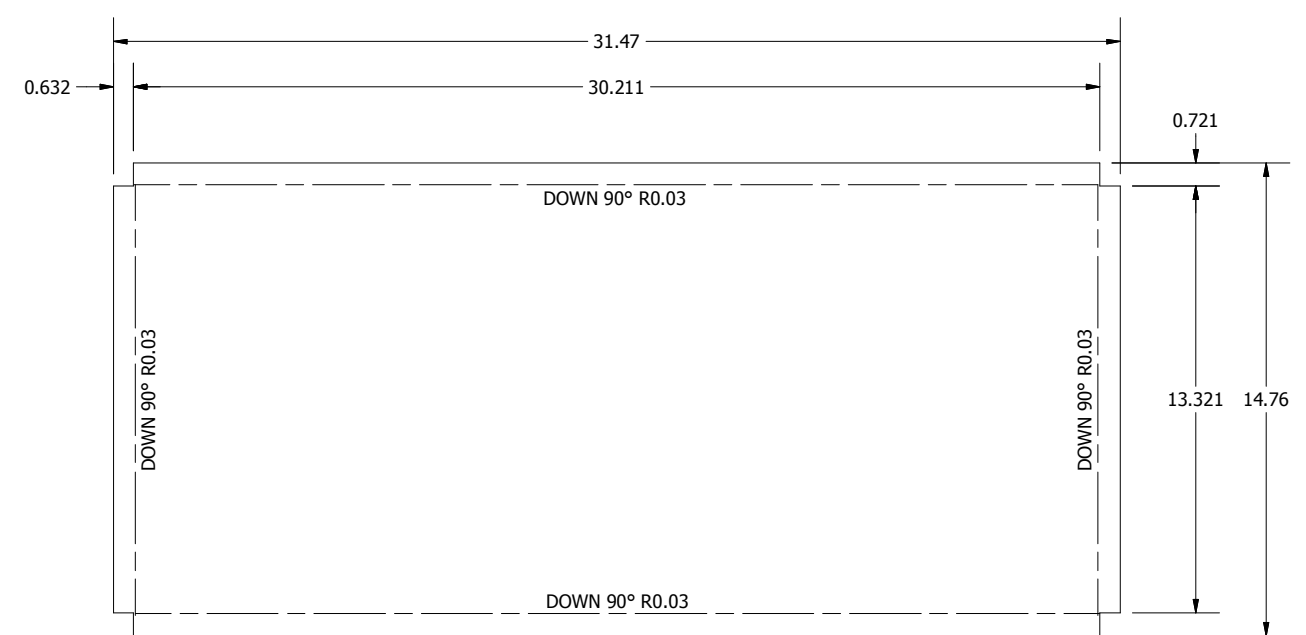

CAP FLAT PATTERN VIEW

FRONT & BACK FLANGES ARE TO OVERLAP SIDE FLANGES



FLAT SIDE VIEW

14 GA. C.R.S. (0.074)

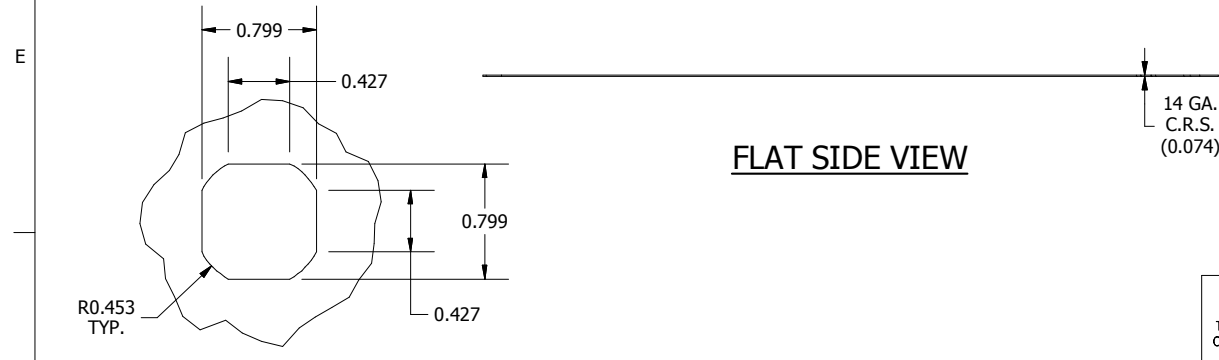

DETAIL D
(LATCH PUNCHING DETAIL)

DIMENSIONS ARE IN INCHES (MM). TOLERANCES UNLESS OTHERWISE SPECIFIED ARE AS FOLLOWS:
.X = ±.06 (1.6)
.XX = ±.031 (.8)
.XXX = ±.016 (.25)
Ø = ±.005
ANGLE TOL ±1'



-NOTICE- THIS DRAWING IS THE PROPERTY OF WIEGMANN, A DIVISION OF HUBBELL INCORPORATED. IT IS LOANED TO YOU AND MUST NOT BE USED IN ANY WAY DETRIMENTAL TO THE INTEREST OF WIEGMANN.

PART NUMBER: RHC3630LID	MATERIAL: SEE NOTE	SCALE: NONE	CHK'D DATE: 7/10/2014
		DRAWN BY: PS	CREATED ON: 7/10/2014
DESCRIPTION: RHC, LID, CS, NEMA 3R, 36X30		CHK'D BY: VR	DWG. NO. HWD RHC363012_2.2
		REV. A	
		SHEET 3 OF 9	

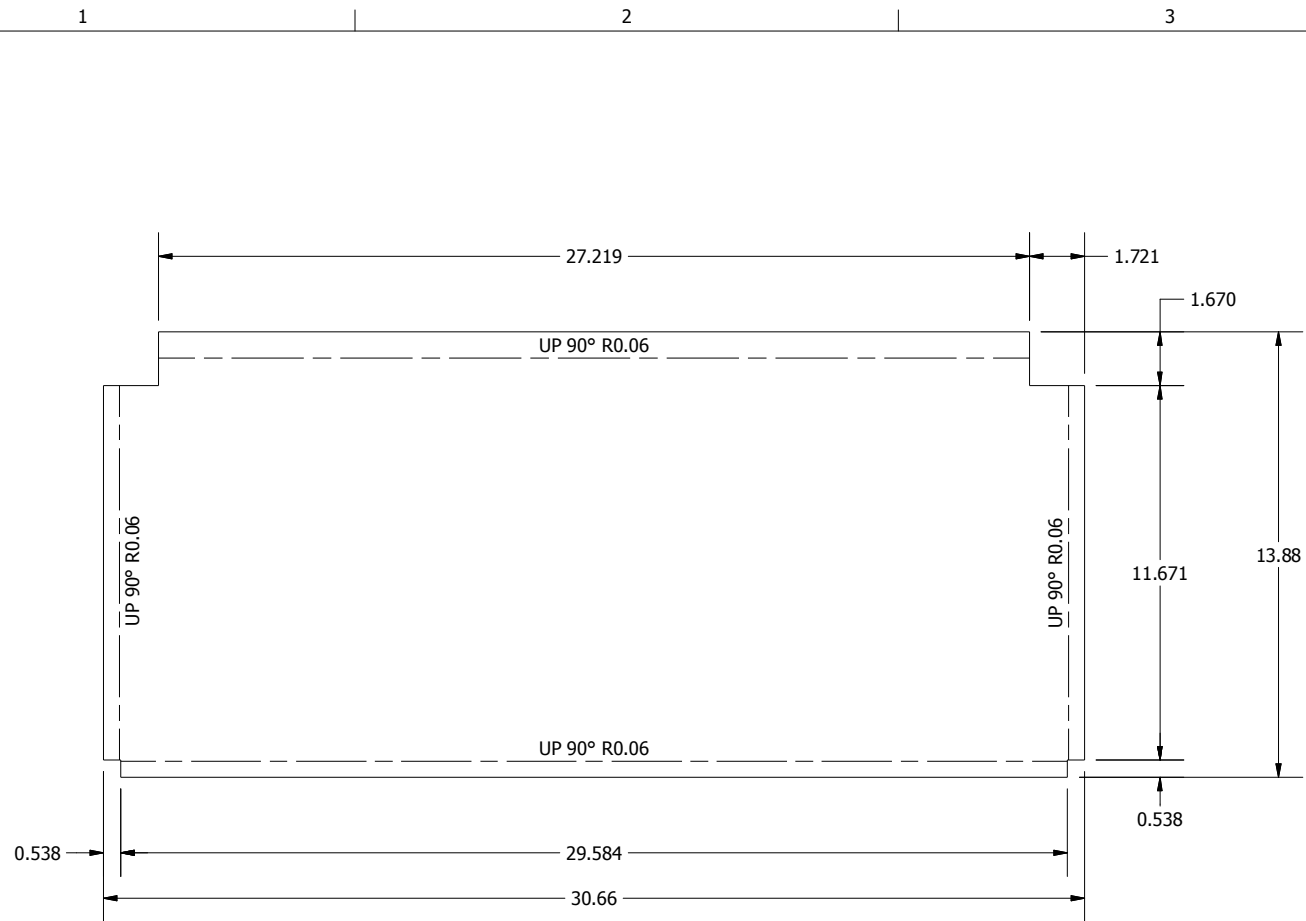

BOTTOM ENDWALL FLAT PATTERN VIEW

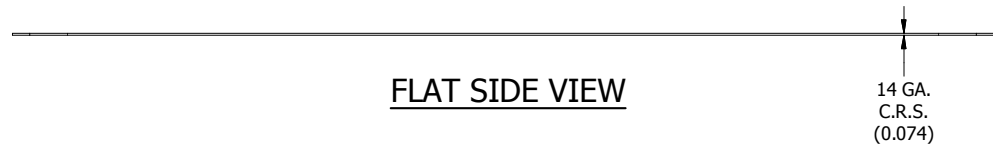

FLAT SIDE VIEW

14 GA.
C.R.S.
(0.074)

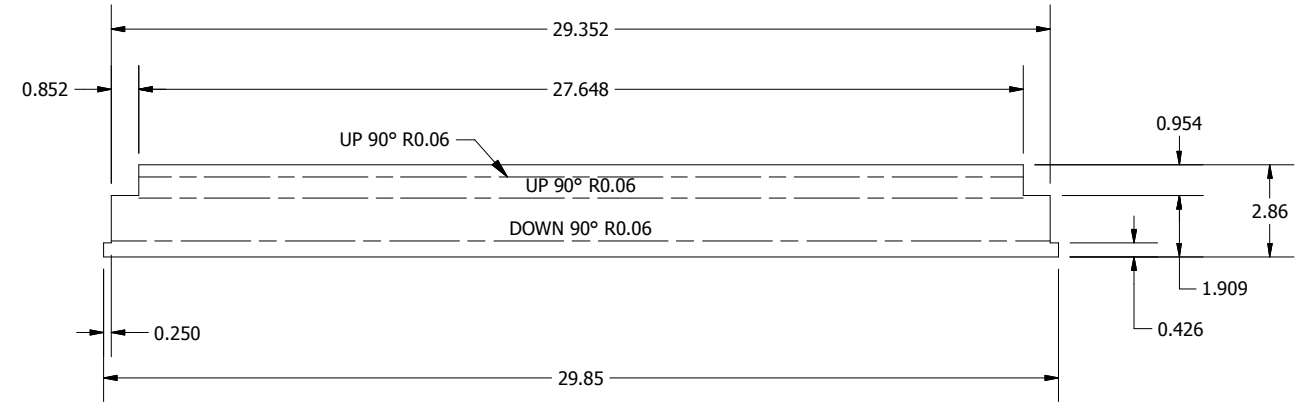

TOP ENDWALL FLAT PATTERN VIEW



FLAT SIDE VIEW

14 GA.
C.R.S.
(0.074)

DIMENSIONS ARE IN INCHES (MM). TOLERANCES UNLESS OTHERWISE SPECIFIED ARE AS FOLLOWS:
.X = ±.06 (1.6)
.XX = ±.031 (.8)
.XXX = ±.016 (.25)
Ø = ±.005
ANGLE TOL ± 1'



WIEGMANN
FREEBURG, ILLINOIS, USA

-NOTICE- THIS DRAWING IS THE PROPERTY OF WIEGMANN, A DIVISION OF HUBBELL INCORPORATED. IT IS LOANED TO YOU AND MUST NOT BE USED IN ANY WAY DETRIMENTAL TO THE INTEREST OF WIEGMANN.

PART NUMBER:
RHC3012BTM

MATERIAL:
SEE NOTE

SCALE: NONE
DRAWN BY: PS
CHK'D BY: VR

CHK'D DATE: 7/10/2014
CREATED ON: 7/10/2014
DWG. NO. HWD RHC363012_2.3
REV. A

DESCRIPTION:
RHC, BTM, CS, NEMA 3R, 30X12

SHEET 4 OF 9

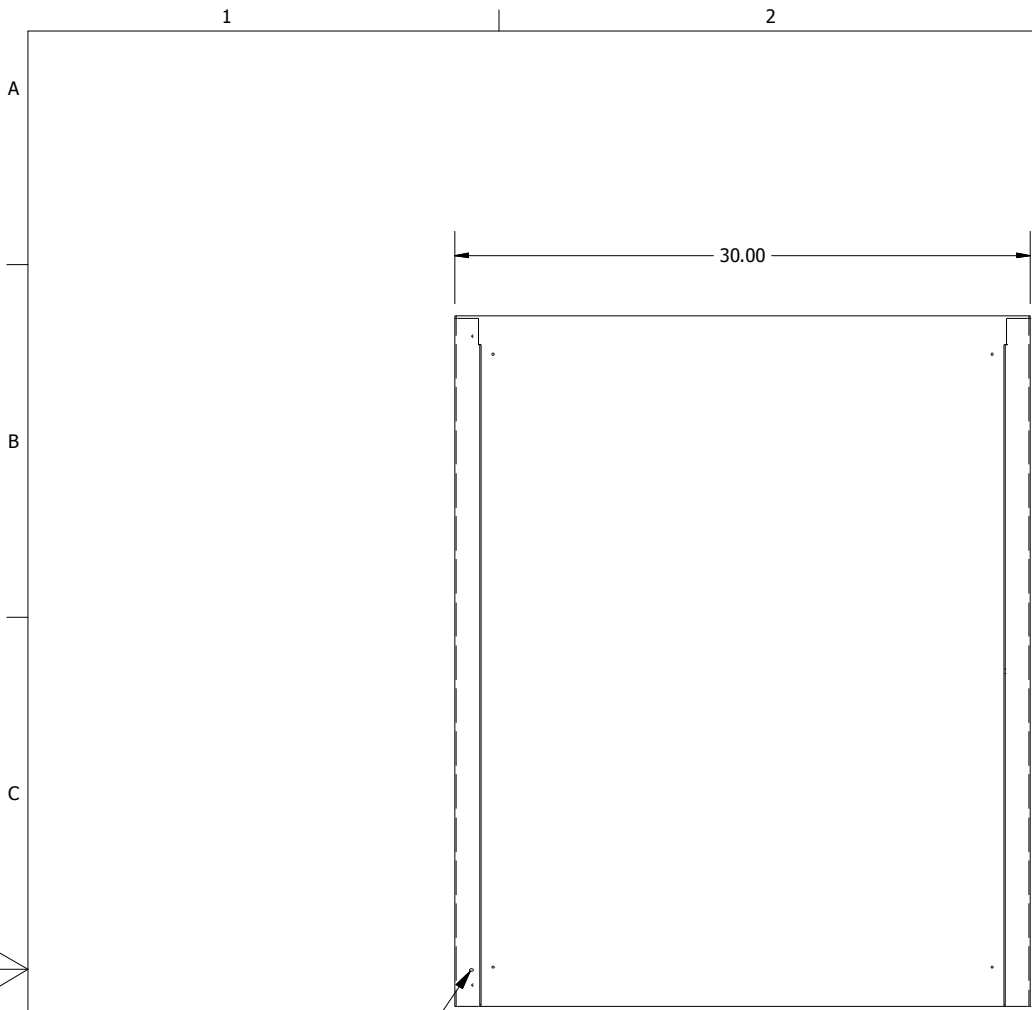

BLR FRONT VIEW

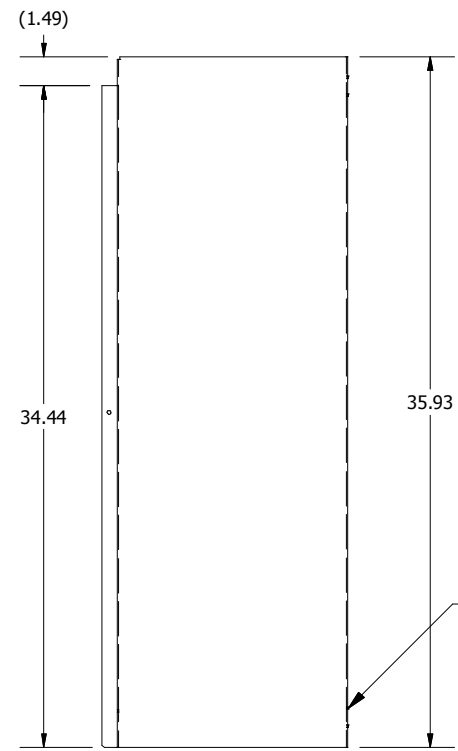

SIDE VIEW

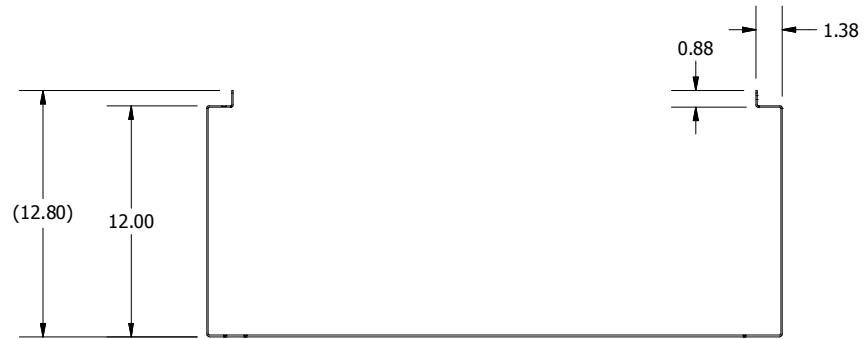
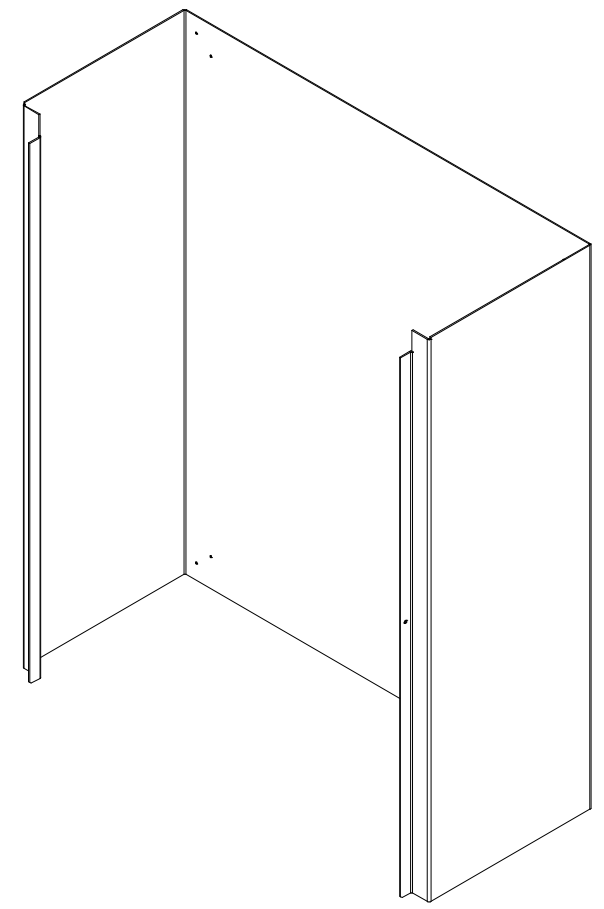

BOTTOM VIEW

DIMENSIONS ARE IN INCHES (MM). TOLERANCES UNLESS OTHERWISE SPECIFIED ARE AS FOLLOWS:
 .X = ±.06 (1.6)
 .XX = ±.031 (.8)
 .XXX = ±.016 (.25)
 Ø = ±.005
 ANGLE TOL ±1°



—NOTICE— THIS DRAWING IS THE PROPERTY OF WIEGMANN, A DIVISION OF HUBBELL INCORPORATED. IT IS LOANED TO YOU AND MUST NOT BE USED IN ANY WAY DETRIMENTAL TO THE INTEREST OF WIEGMANN.

PART NUMBER: RHC363012BLR	MATERIAL: SEE NOTE	SCALE: NONE	CHK'D DATE: 7/10/2014
		DRAWN BY: PS	CREATED ON: 7/10/2014
DESCRIPTION: RHC, BLR, MEDIUM, CS, 36X30X12		CHK'D BY: VR	DWG. NO. HWRHC363012_3.1
		REV. A	
		SHEET 5 OF 9	

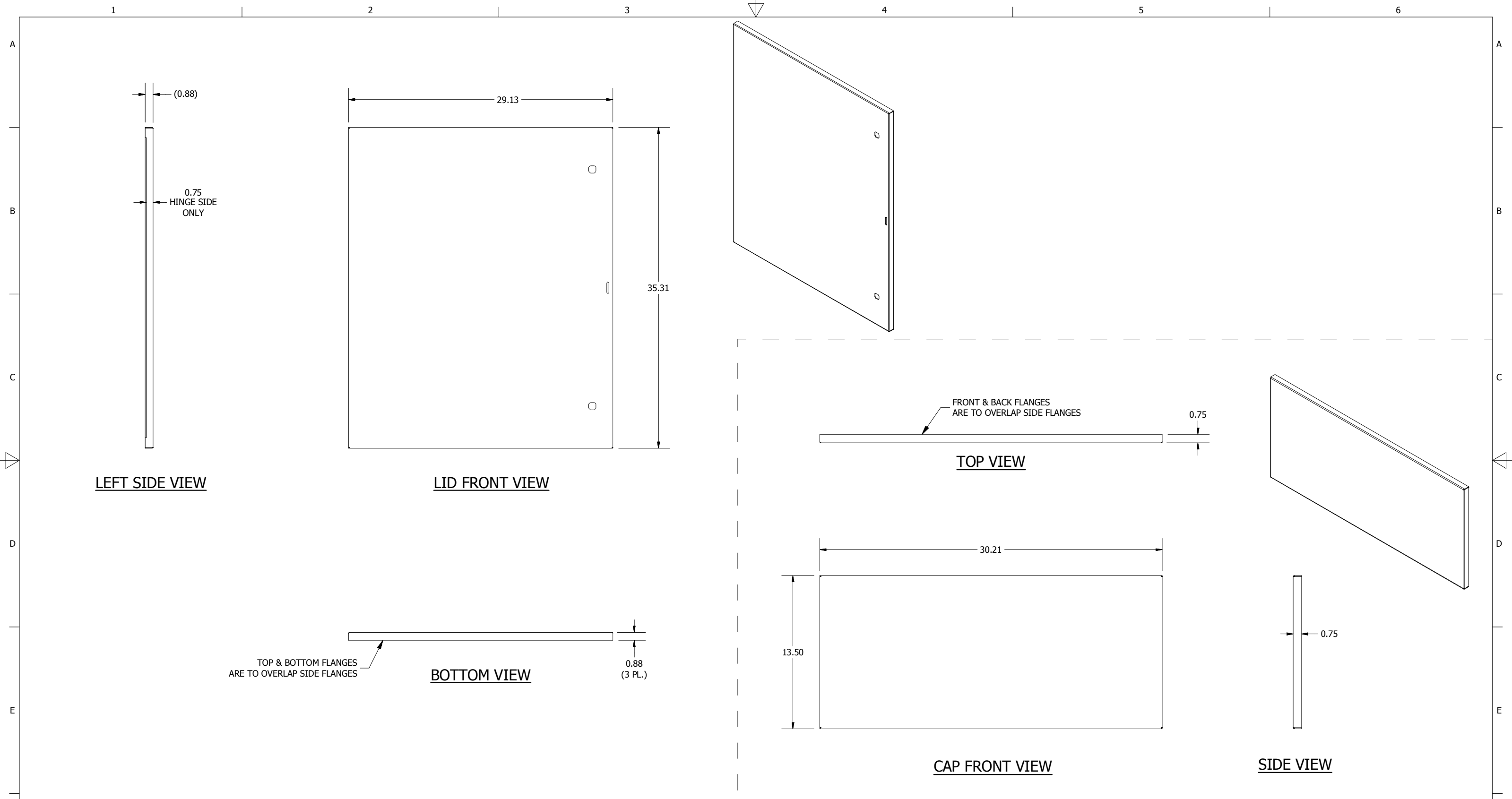

DIMENSIONS ARE IN INCHES (MM). TOLERANCES UNLESS OTHERWISE SPECIFIED ARE AS FOLLOWS:
 .X = ±.06 (1.6)
 .XX = ±.031 (.8)
 .XXX = ±.016 (.25)
 Ø = ±.005
 ANGLE TOL ±1'



WIEGMANN
 FREEBURG, ILLINOIS, USA

—NOTICE— THIS DRAWING IS THE PROPERTY OF WIEGMANN, A DIVISION OF HUBBELL INCORPORATED. IT IS LOANED TO YOU AND MUST NOT BE USED IN ANY WAY DETRIMENTAL TO THE INTEREST OF WIEGMANN.

PART NUMBER: RHC3630LID	MATERIAL: SEE NOTE	SCALE: NONE	CHK'D DATE: 7/10/2014
		DRAWN BY: PS	CREATED ON: 7/10/2014
DESCRIPTION: RHC, LID, CS, NEMA 3R, 36X30		CHK'D BY: VR	DWG. NO. HWD RHC363012_3.2
		REV. A	
SHEET 6 OF 9		6	

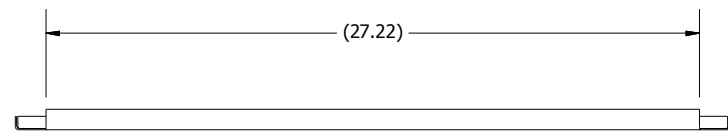

BOTTOM ENDWALL FRONT VIEW

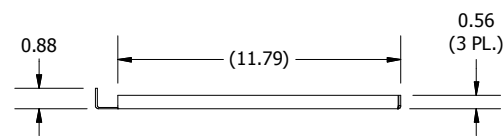

SIDE VIEW

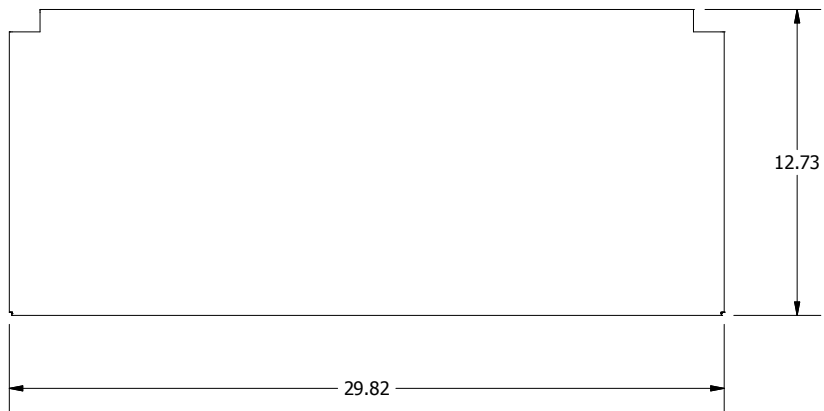

BOTTOM VIEW

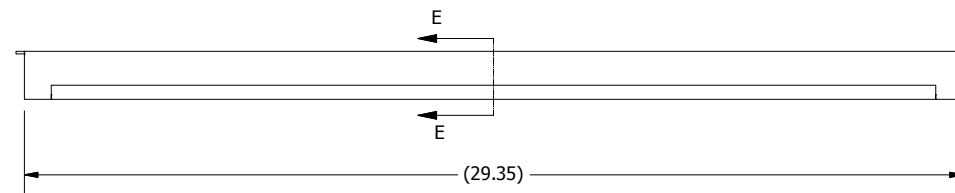
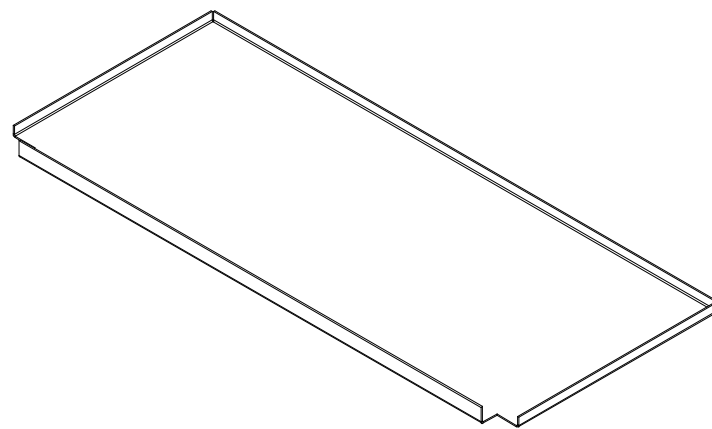

TOP ENDWALL FRONT VIEW

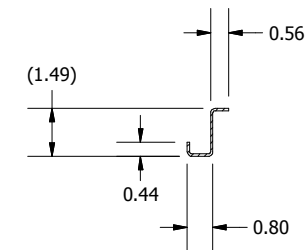

SECTION E-E

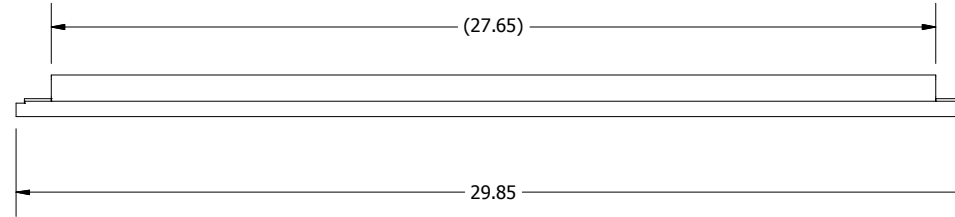

BOTTOM VIEW

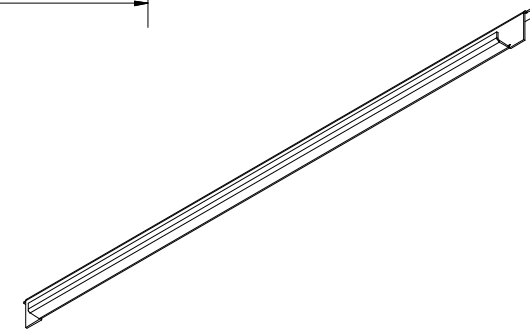

DIMENSIONS ARE IN INCHES (MM). TOLERANCES UNLESS OTHERWISE SPECIFIED ARE AS FOLLOWS:
 .X = ±.06 (1.6)
 .XX = ±.031 (.8)
 .XXX = ±.016 (.25)
 Ø = ±.005
 ANGLE TOL ±1°



WIEGMANN
 FREEBURG, ILLINOIS, USA

—NOTICE— THIS DRAWING IS THE PROPERTY OF WIEGMANN, A DIVISION OF HUBBELL INCORPORATED. IT IS LOANED TO YOU AND MUST NOT BE USED IN ANY WAY DETRIMENTAL TO THE INTEREST OF WIEGMANN.

PART NUMBER:
RHC3012BTM

MATERIAL:
SEE NOTE

SCALE: NONE
 DRAWN BY: PS
 CHK'D BY: VR

CHK'D DATE: 7/10/2014
 CREATED ON: 7/10/2014

DESCRIPTION:
RHC, BTM, CS, NEMA 3R, 30X12

DWG. NO. HWDRHC363012_3.3
 REV. A

SHEET 7 OF 9

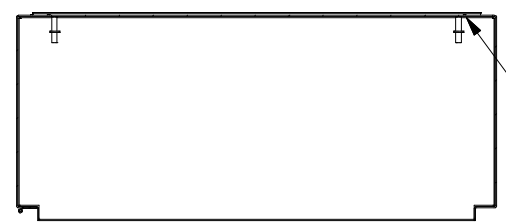

SECTION H-H

TACK WELD BOTTOM ENDWALL TO INSIDE OF BLR ON SIDES EVENLY & THROUGHOUT

SPOT WELD HINGE TO TUB FLANGE EVENLY & THROUGHOUT

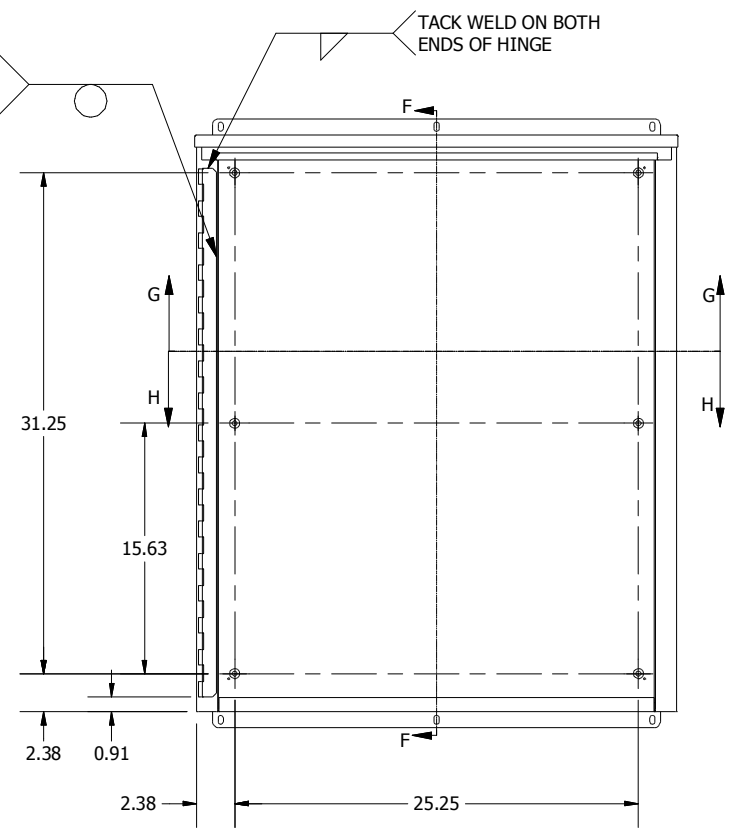

TUB WELD FRONT VIEW

TACK WELD ON BOTH ENDS OF HINGE

TACK WELD MTG. FOOT ON THREE SIDES TO BACK OF TUB EVENLY & THROUGHOUT (2 PL.)

TOP ENDWALL OVERLAPS BLR FLANGE

CD WELD 3/8-16 COLLAR STUD (6 PL.)

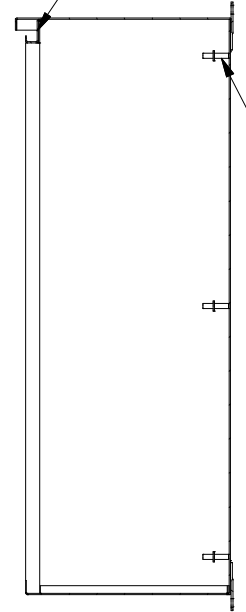

SECTION F-F

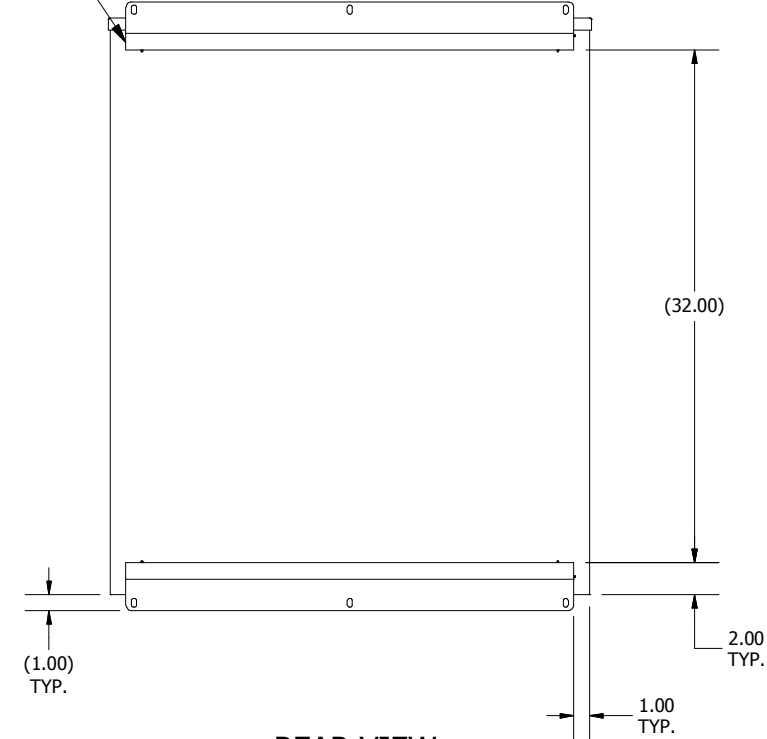

REAR VIEW

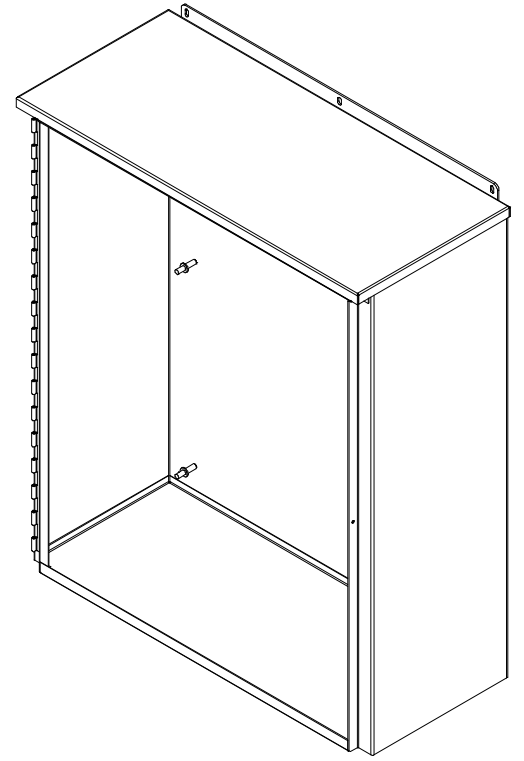

SECTION G-G

TACK WELD CAP TO ALL BLR & TOP ENDWALL FLANGES EVENLY & THROUGHOUT

DIMENSIONS ARE IN INCHES (MM). TOLERANCES UNLESS OTHERWISE SPECIFIED ARE AS FOLLOWS:
 .X = ±.06 (1.6)
 .XX = ±.031 (.8)
 .XXX = ±.016 (.25)
 Ø = ±.005
 ANGLE TOL ±1'



WIEGMANN
 FREEBURG, ILLINOIS, USA

—NOTICE— THIS DRAWING IS THE PROPERTY OF WIEGMANN, A DIVISION OF HUBBELL INCORPORATED. IT IS LOANED TO YOU AND MUST NOT BE USED IN ANY WAY DETRIMENTAL TO THE INTEREST OF WIEGMANN.

PART NUMBER:
 RHC363012

MATERIAL:
 SEE NOTE

SCALE: NONE
 DRAWN BY: PS
 CHK'D BY: VR

CHK'D DATE: 7/10/2014
 CREATED ON: 7/10/2014
 DWG. NO. HWDRHC363012_4.1
 REV. A

DESCRIPTION:
 RHC, NEMA 3R ENCL., CS, 36X30X12

SHEET 8 OF 9

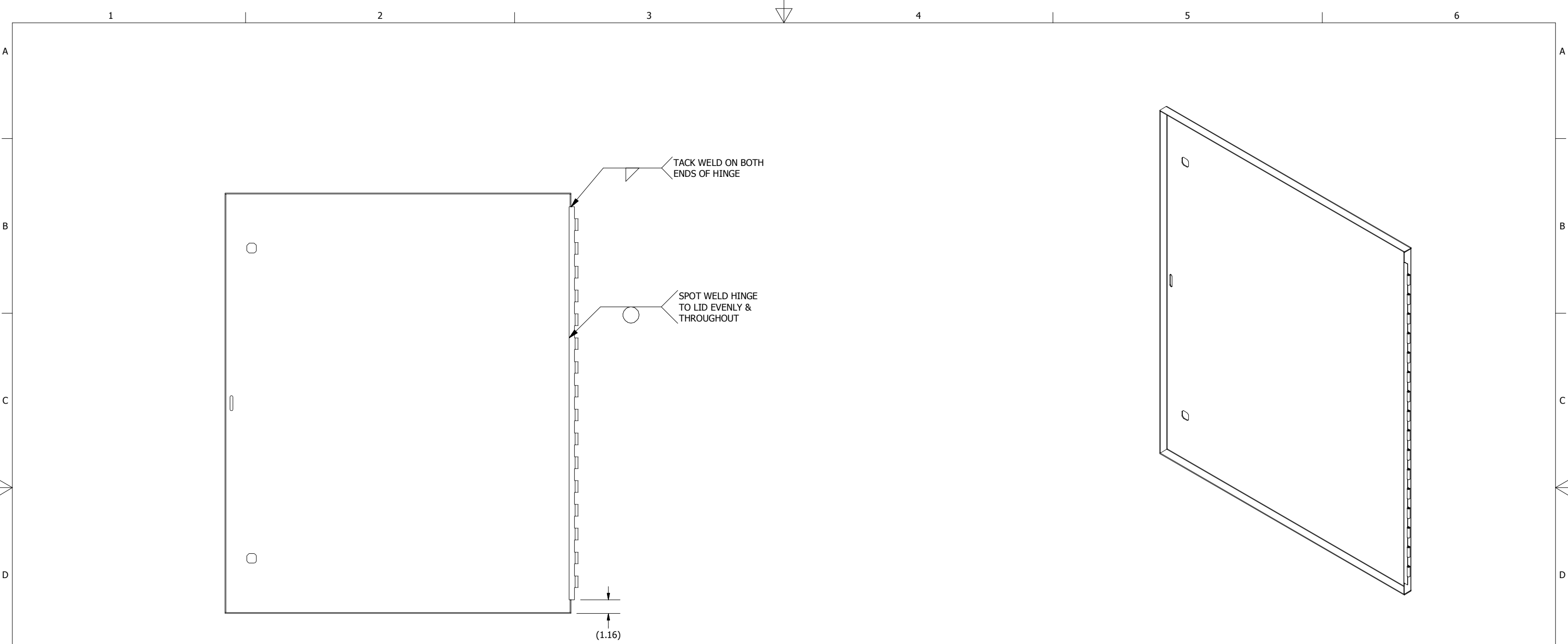

LID WELD INSIDE VIEW

DIMENSIONS ARE IN INCHES (MM). TOLERANCES UNLESS OTHERWISE SPECIFIED ARE AS FOLLOWS:
 .X = ±.06 (1.6)
 .XX = ±.031 (.8)
 .XXX = ±.016 (.25)
 Ø = ±.005
 ANGLE TOL ±1°



WIEGMANN
 FREEBURG, ILLINOIS, USA

—NOTICE— THIS DRAWING IS THE PROPERTY OF WIEGMANN, A DIVISION OF HUBBELL INCORPORATED. IT IS LOANED TO YOU AND MUST NOT BE USED IN ANY WAY DETRIMENTAL TO THE INTEREST OF WIEGMANN.

PART NUMBER:
 RHC363012

MATERIAL:
 SEE NOTE

SCALE: NONE
 DRAWN BY: PS
 CHK'D BY: VR

CHK'D DATE: 7/10/2014
 CREATED ON: 7/10/2014
 DWG. NO. HWDRHC363012_4.2
 REV. A

DESCRIPTION:
 RHC, NEMA 3R ENCL., CS, 36X30X12

SHEET 9 OF 9