

BALDOR® • RELIANCE 

Product Information Packet

UCLE7510

7.5-10 AIR OVERHP,3450RPM,1PH,60HZ,182TZ

Part Detail							
Revision:	H	Status:	PRD/A	Change #:		Proprietary:	No
Type:	AC	Elec. Spec:	36WGX955	CD Diagram:	CD0208	Mfg Plant:	
Mech. Spec:	36Q215	Layout:	36LYQ215	Poles:	02	Created Date:	03-06-2014
Base:	RG	Eff. Date:	03-05-2018	Leads:	2#10 A PH SEE NOTES,3#16 B PH		Y

Specs			
Catalog Number:	UCLE7510	Inverter Code:	Not Inverter
Enclosure:	TEAO	KVA Code:	F
Frame:	182TZ	Lifting Lugs:	Standard Lifting Lugs
Frame Material:	Steel	Locked Bearing Indicator:	Locked Bearing
Output @ Frequency:	7.500 HP @ 60 HZ	Motor Lead Quantity/Wire Size:	2 @ 10 AWG, A PH
	10.000 HP @ 60 HZ	Motor Lead Exit:	Pipe Or Pipe Adaptor
Synchronous Speed @ Frequency:	3600 RPM @ 60 HZ	Motor Lead Termination:	Flying Leads
Voltage @ Frequency:	230.0 V @ 60 HZ	Motor Type:	3646LC
XP Class and Group:	None	Mounting Arrangement:	F1
XP Division:	Not Applicable	Power Factor:	95
Agency Approvals:	UR	Product Family:	General Purpose
	CSA	Product Type:	FARM DUTY
Auxillary Box:	No Auxillary Box	Pulley End Bearing Type:	Ball
Auxillary Box Lead Termination:	None	Pulley Face Code:	Standard
Base Indicator:	Rigid	Pulley Shaft Indicator:	Tapped & Key
Bearing Grease Type:	Polyrex EM (-20F +300F)	Rodent Screen:	None
Blower:	None	RoHS Status:	ROHS COMPLIANT
Current @ Voltage:	28.000 A @ 208.0 V	Shaft Extension Location:	Pulley End

	38.000 A @ 230.0 V	Shaft Ground Indicator:	No Shaft Grounding
Design Code:	-	Shaft Rotation:	Reversible
Drip Cover:	No Drip Cover	Shaft Slinger Indicator:	Shaft Slinger
Duty Rating:	CONT	Speed Code:	Single Speed
Electrically Isolated Bearing:	Not Electrically Isolated	Motor Standards:	NEMA
Feedback Device:	NO FEEDBACK	Starting Method:	Direct on line
Front Face Code:	Standard	Thermal Device - Bearing:	NONE (OLD)
Front Shaft Indicator:	None	Thermal Device - Winding:	Normally Closed Thermostat
Heater Indicator:	No Heater	Vibration Sensor Indicator:	No Vibration Sensor
Insulation Class:	F	Winding Thermal 1:	None
		Winding Thermal 2:	None

Nameplate NP1279L										
CAT.NO.	UCLE7510									
SPEC.	36Q215X955G1									
HP	7.5-10 AIR OVER									
VOLTS	230									
AMP	38									
RPM	3450									
FRAME	182TZ			HZ	60		PH	1		
SER.F.	1.00			CODE	F		DES	-		
NEMA-NOM-EFF	85.5			PF	95		CL	F		
RATING	40C AMB-CONT									
CC							USABLE AT 208V	28		
DE	6206			ODE	6205					
ENCL	TEAO			SN						

Nameplate NP1263L	
CAT.NO.	UCLE7510
SPEC.	36Q215X955G1
HP	7.5-10 AIR OVER
VOLTS	230
AMP	38
RPM	3450
FRAME	182TZ
HZ	60
PH	1
SER.F.	1.00
CODE	F
DES	-
CL	F
NEMA-NOM-EFF	85.5
PF	95
RATING	40C AMB-CONT
CC	USABLE AT 208V 28
DE	6206
ODE	6205
ENCL	TEAO
SN	

Parts List		
Part Number	Description	Quantity
SA277503	SA 36Q215X955G1	1.000 EA
RA264052	RA 36Q215X955G1	1.000 EA
OC3050F09SP	CAPACITOR 50 MFD 370 VAC	2.000 EA
OC3040F18SP	7YL OIL CAP 40MFD/370V	1.000 EA
EC1216C06SP	ELEC CAP, 216-259 MFD, 250V, 2.06D X 4.	1.000 EA
HA6021A01SP	ADAPTOR, MACH	1.000 EA
51XB1016A07	10-16 X 7/16 HXWSSLD SERTYB	2.000 EA
36GS5000	GASKET CONDUIT ADAPTOR	1.000 EA
11XW1032G06	10-32 X .38, TAPTITE II, HEX WSHR SLTD U	1.000 EA
HW3001B01	BRASS CUP WASHER, FOR #10 SCREW	1.000 EA
36EP3104A46	FREP TENV 36L/M 205 BRG NO GR SR, W/GND	1.000 EA
13XF0832A08	8-32 X.50 PAN HD,SLTD, TYPE F SCREW, ZIN	2.000 EA
51XB1016A05	10-16X5/16HX WA SL SR TYB (F/S)	2.000 EA
HW5100A05	WVY WSHR F/205 & 304 BRGS	1.000 EA
36PE3100B94	PUEP ASSEMBLY FOR ROUTING PURPOSES	1.000 EA
HW4600B50SP	SEAL 1.156 X 1.874 X 0.250 SINGLE LIP DB	1.000 EA
10XN2520A20	1/4-20X 1 1/4 HEX HD X	2.000 EA
XY2520A12	1/4-20 HEX NUT, DIRECTIONAL SERRATIONS	4.000 EA
HW4600B36SP	V-RING SLINGER 1.188 X 1.690 X .24 VITON	1.000 EA
HW2501E18	KEY, 1/4 SQ X 2.000	1.000 EA
HA7000A02	KEY RETAINER RING, 1 1/8 DIA, 1 3/8 DIA	1.000 EA
85XU0407S04	4X1/4 U DRIVE PIN STAINLESS	2.000 EA
34GS5003	OAM SLEEVE, ID = 2 1/16" X 3 3/8"	3.000 EA
HW3200A01	3/8-16X3/4 I-BLT WELDED F/S	1.000 EA

Parts List (continued)		
Part Number	Description	Quantity
MJ1000A02	GREASE, POLYREX EM EXXON (USe 4824-15A)	0.050 LB
LB1115N	LABEL,LIFTING DEVICE (ON ROLLS)	1.000 EA
MG1025C02	WILKOFASST SG, 787.105, TAN	0.022 GA
WD1000A15	3-520132-2 AMP FLAG (4M/RL NON-CANC/NON-	8.000 EA
35CB4802A02SP	CAPACITOR COVER, STAMPED X	1.000 EA
35GS3001A02	GASKET, CA.COVER, 5.38 LONG .06 CS301	1.000 EA
SP5172A11	37 TYPE LC TORQ STAT SWITCH LEAD ASSEMBL	1.000 EA
HA3101A28	THRUBOLT 1/4-20 X 12.500 OHIO ROD	4.000 EA
MP1002A24	6" X 16" .65 MIL. CLEAR PLASTIC BAG	1.000 EA
LB1119N	WARNING LABEL	1.000 EA
LC0208	CONNECTION LABEL	1.000 EA
NP1279L	ALUM FARM DUTY UL CSA CC	1.000 EA
NP1263L	AUX, GP, ALUM, CC, LASER ETCHED	1.000 EA
LD5000A24	LEAD ASSY, ML1400DF10 W/#10 RING 12"	1.000 EA
36PA1001	PKG GRP, PRINT PK1017A06	1.000 EA
MN416A01	TAG-INSTAL-MAINT no wire (1200/bx) 5/18	1.000 EA

Accessories		
Part Number	Description	Multiplier
36-3301	C FACE KIT	A8
36EP1304A62SP	FLANGE MTD ENDPLATE 182-4TD -ENCL (LESS	A8

AC Induction Motor Performance Data

Record # 11173 - Typical performance - not guaranteed values

Winding: 36WGX955-R001	Type: 3646LC	Enclosure: TEAO
-------------------------------	---------------------	------------------------

Nameplate Data				230 V, 60 Hz: Single Voltage Motor	
Rated Output (HP)	7.5-10 AIR OVER			Full Load Torque	15.2 LB-FT
Volts	230			Start Configuration	direct on line
Full Load Amps	38			Breakdown Torque	41.5 LB-FT
R.P.M.	3450			Pull-up Torque	4 LB-FT
Hz	60	Phase	1	Locked-rotor Torque	4.5 LB-FT
NEMA Design Code	-	KVA Code	F	Starting Current	213 A
Service Factor (S.F.)	1			No-load Current	6.2 A
NEMA Nom. Eff.	85.5	Power Factor	95	Line-line Res. @ 25°C	0.202 Ω A Ph 0.319 Ω B Ph
Rating - Duty	40C AMB-CONT			Temp. Rise @ Rated Load	

Load Characteristics 230 V, 60 Hz, 10 HP

% of Rated Load	25	50	75	100	125	150
Power Factor	95	99	99	99	99	99
Efficiency	67.3	80.6	84.8	85.7	84.7	82.4
Speed	3565	3533	3498	3458	3412	3357
Line amperes	12.8	20.4	28.8	37.9	47.9	59.4

Performance Graph at 230V, 60Hz, 10.0HP Typical performance - Not guaranteed values

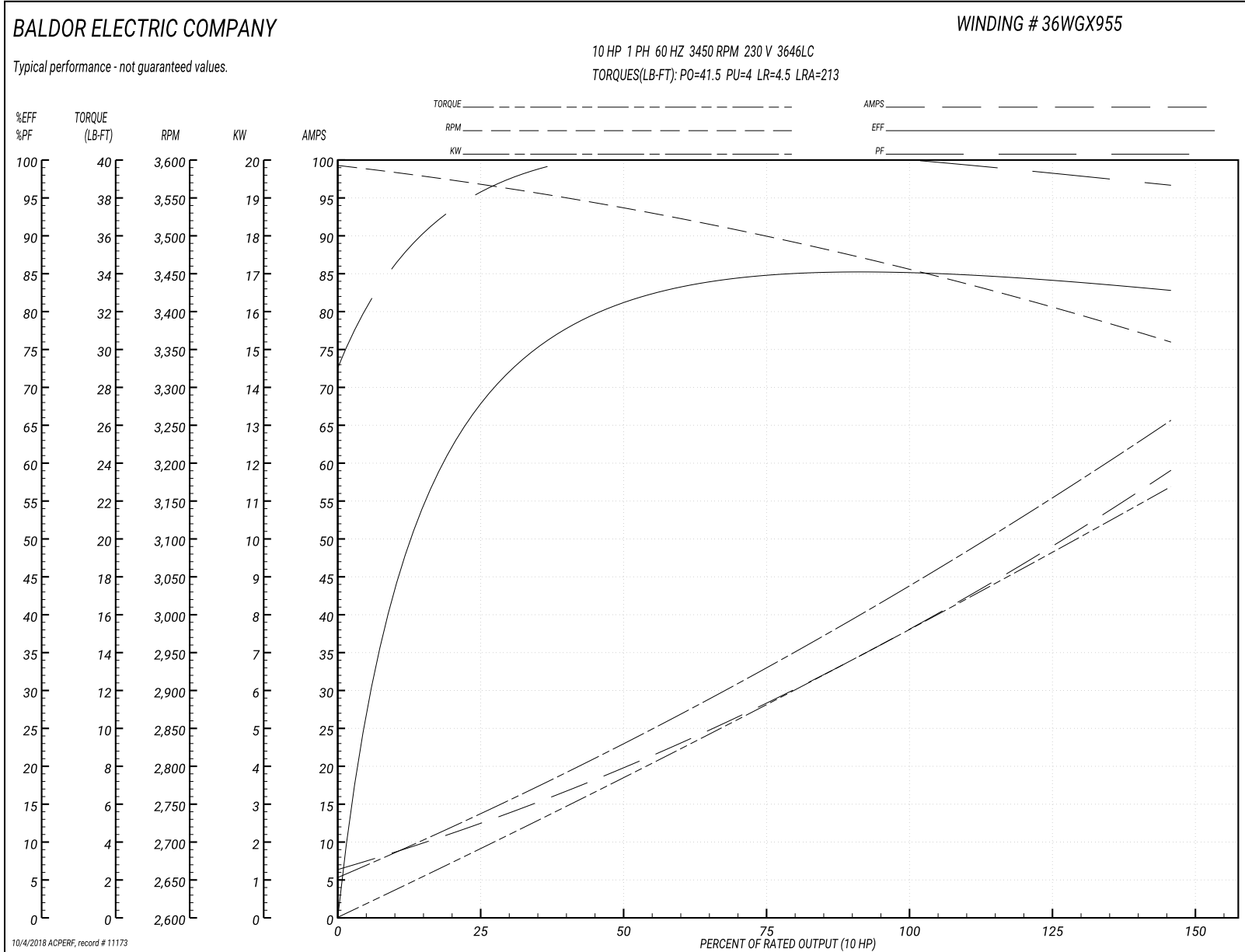

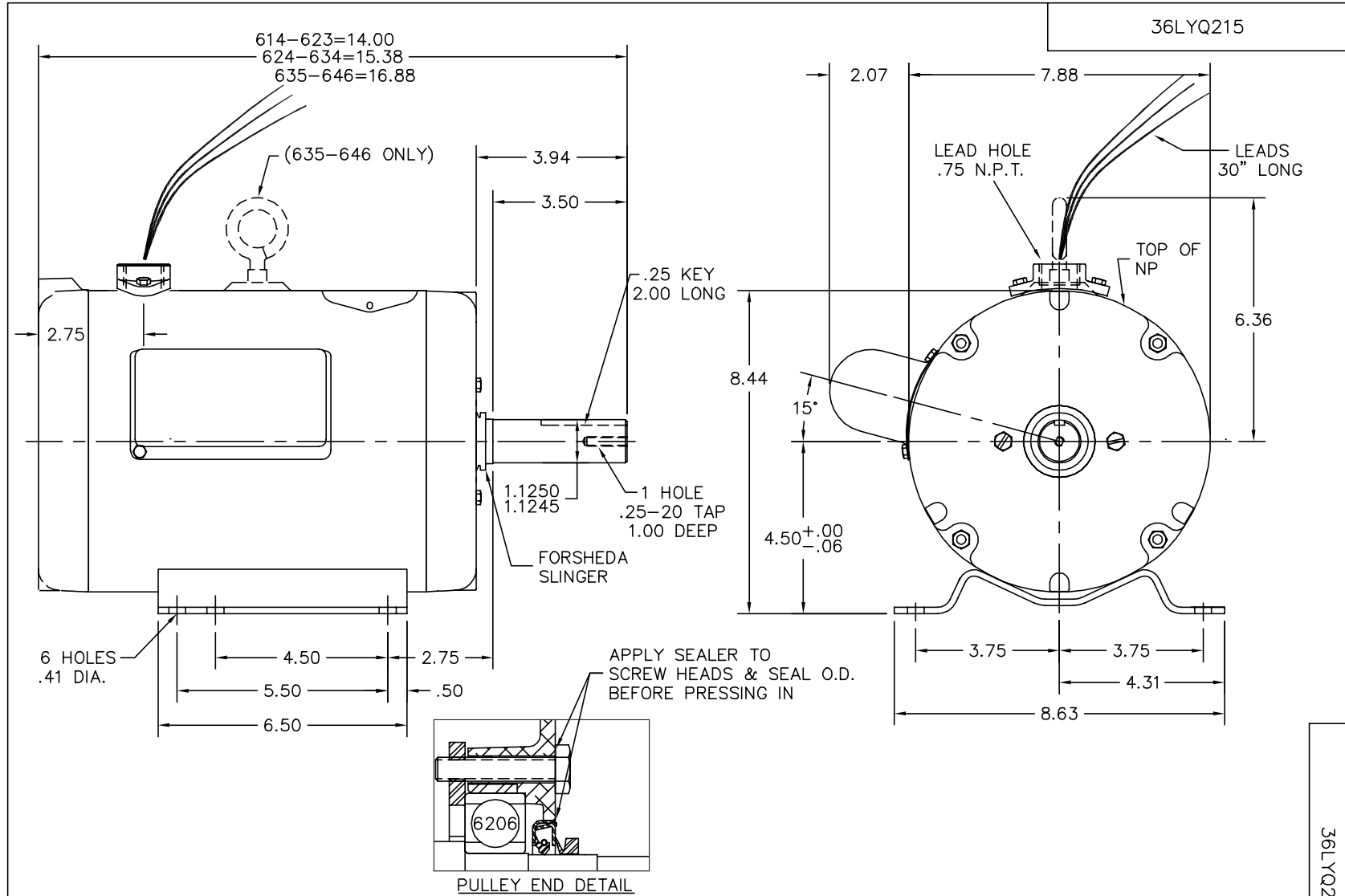

CUSTOMER IS RESPONSIBLE FOR DETERMINING THAT BALDOR'S PRODUCT WILL PERFORM SUITABLY IN THE INTENDED APPLICATION.

REV. DESC: CHG FREP TO 36EP3104A46		
REV. LTR: B	VERSION: 02	TDR: 000000919753
FILE: \AAA\00207\435	REVISED: 08:56:53 05/06/2015	BY: FGCHAH1
MTL: -		

BALDOR

HOR 182-4TZ TENV 36L-LC CROP DRYER T'STATS, CAP.CAN @10 SEAL

SH 1 of 1

36LYQ215

CD0208

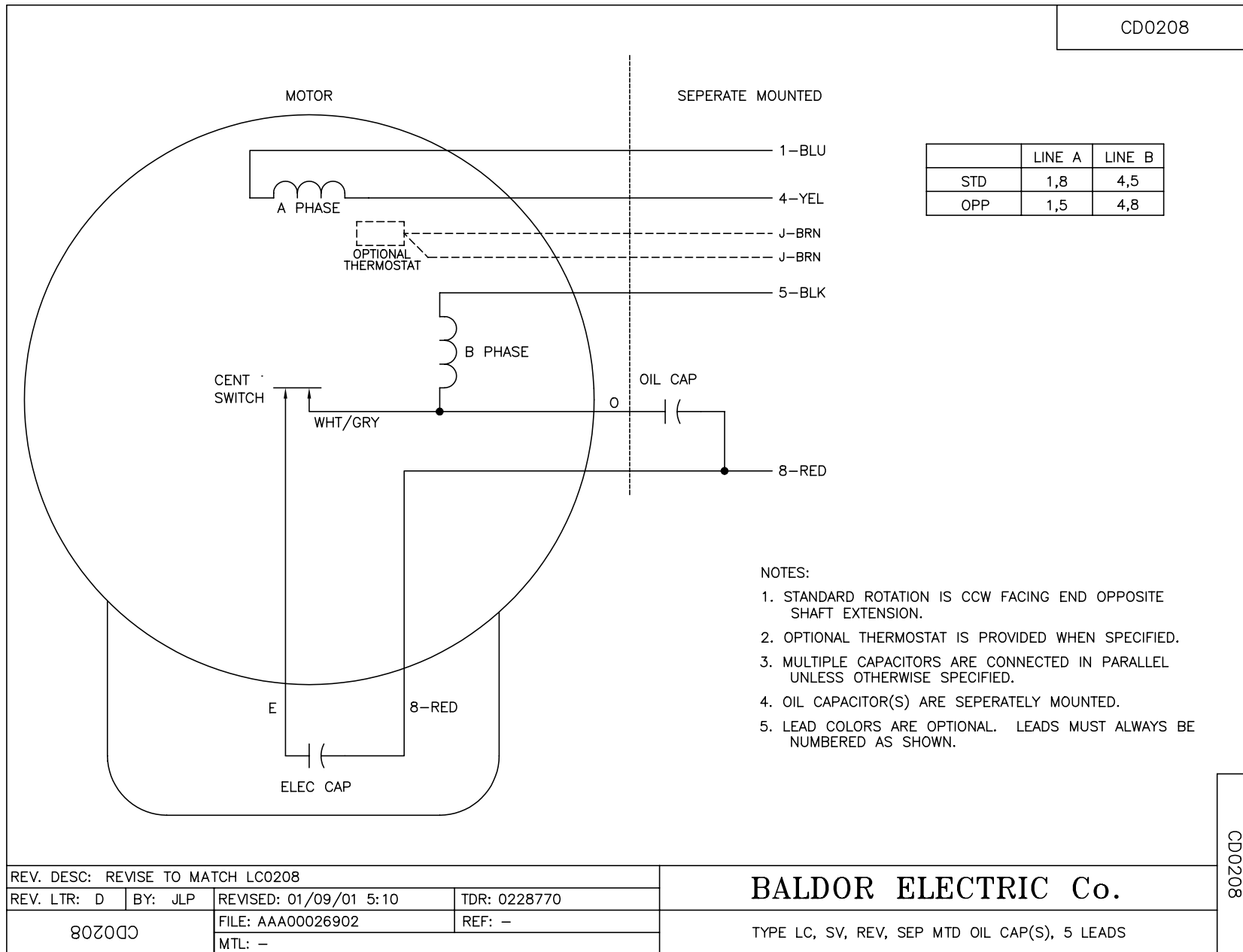

REV. DESC: REVISE TO MATCH LC0208			
REV. LTR: D	BY: JLP	REVISED: 01/09/01 5:10	TDR: 0228770
80200		FILE: AAA00026902	REF: -
		MTL: -	

BALDOR ELECTRIC Co.

TYPE LC, SV, REV, SEP MTD OIL CAP(S), 5 LEADS

CD0208