

BALDOR® • RELIANCE 

Product Information Packet

VEBM3554T-5D

1.5HP, 1760RPM, 3PH, 60HZ, 145TC, 3526M, TEFC

Part Detail							
Revision:	L	Status:	PRD/A	Change #:		Proprietary:	No
Type:	AC	Elec. Spec:	35WGM887	CD Diagram:	CD0006	Mfg Plant:	
Mech. Spec:	35X050	Layout:	35LYX050	Poles:	04	Created Date:	09-28-2010
Base:	N	Eff. Date:	06-28-2018	Leads:	3#18		

Specs			
Catalog Number:	VEBM3554T-5D	Inverter Code:	Inverter Ready
Enclosure:	TEFC	KVA Code:	L
Frame:	145TC	Lifting Lugs:	No Lifting Lugs
Frame Material:	Steel	Locked Bearing Indicator:	Locked Bearing
Output @ Frequency:	1.500 HP @ 60 HZ	Motor Lead Quantity/Wire Size:	3 @ 18 AWG
Synchronous Speed @ Frequency:	1800 RPM @ 60 HZ	Motor Lead Exit:	Ko Box
Voltage @ Frequency:	575.0 V @ 60 HZ	Motor Lead Termination:	Flying Leads
XP Class and Group:	None	Motor Type:	3526M
XP Division:	Not Applicable	Mounting Arrangement:	F3
Agency Approvals:	UR	Power Factor:	73
	WEEE	Product Family:	General Purpose
	CSA	Product Type:	D-SERIES BRAKE MOTORS
	CE	Pulley End Bearing Type:	Sealed Bearing
Auxillary Box:	No Auxillary Box	Pulley Face Code:	C-Face
Auxillary Box Lead Termination:	None	Pulley Shaft Indicator:	Standard
Base Indicator:	No Mounting	Rodent Screen:	None
Bearing Grease Type:	Polyrex EM (-20F +300F)	Shaft Extension Location:	Pulley End
Blower:	None	Shaft Ground Indicator:	No Shaft Grounding

Current @ Voltage:	1.800 A @ 575.0 V	Shaft Rotation:	Reversible
Design Code:	B	Shaft Slinger Indicator:	No Slinger
Drip Cover:	No Drip Cover	Speed Code:	Single Speed
Duty Rating:	CONT	Motor Standards:	NEMA
Electrically Isolated Bearing:	Not Electrically Isolated	Starting Method:	Direct on line
Feedback Device:	NO FEEDBACK	Thermal Device - Bearing:	NONE (OLD)
Front Face Code:	Fan Housing Cover For Brake	Thermal Device - Winding:	None
Front Shaft Indicator:	None	Vibration Sensor Indicator:	No Vibration Sensor
Heater Indicator:	No Heater	Winding Thermal 1:	None
Insulation Class:	F	Winding Thermal 2:	None

Nameplate NP2105L										
CAT.NO.	VEBM3554T-5D									
SPEC.	35X050M887G1									
HP	1.5									
VOLTS	575									
AMP	1.8									
RPM	1760									
FRAME	145TC			HZ	60			PH	3	
SER.F.	1.15			CODE	L		DES	B	CL	F
NEMA-NOM-EFF	86.5			PF	73					
RATING	40C AMB-CONT									
CC	010A						USABLE AT 208V			
DE	6205			ODE	6205					
ENCL	TEFC			SN						
	IP44									

Parts List		
Part Number	Description	Quantity
SA203771	SA 35X050M887G1	1.000 EA
RA191030	RA 35X050M887G1	1.000 EA
S/P111-000-002	CORONA TEST, SUPER E MOTORS - FT. SMITH	1.000 EA
NS2512A01	INSULATOR, CONDUIT BOX X	1.000 EA
35CB4007	KOBX,W/PRIMER (REL# 79097-49-C)	1.000 EA
35GS3009	GASKET, KOBX 35CB4006 (411881-15A)	1.000 EA
WD4101A13	STEEL CAPLUG,BP-1 1/8, PLUG D3561S	1.000 EA
51XB1016A05	10-16X5/16HX WA SL SR TYB (F/S)	2.000 EA
11XW1032G06	10-32 X .38, TAPTITE II, HEX WSHR SLTD U	1.000 EA
HW3001B02	BRASS CUP WASHER W/GROUND SYMBOL TAB,	1.000 EA
35EP3119A01	SPL FREP TEFC 205 BRG	1.000 EA
HW5100A05	WVY WSHR F/205 & 304 BRGS	1.000 EA
35EP3307F00	MASTER DE,205 BRG,.998SH,#26 DRN	1.000 EA
51XN1032A20	10-32 X 1 1/4 HX WS SL SR	2.000 EA
35FH3004A01	FAN COVER ASSY, BRAKE MTG	1.000 EA
51XN1032A32	10-32 X 2 HX WS SL SR	4.000 EA
BR2006B01	DBSC SPLINED HUB 5/8 BOR	1.000 EA
35FN3003A01	EXFN, PLASTIC, 5.88 OD, .626 ID	1.000 EA
35CB4519	CB LID RAW & UNPRIMED, REL# 79097-50-B	1.000 EA
35GS3019A01	LEXIDE GASKET, FOR KOBX LID 35CB4519	1.000 EA
51XW0832A07	8-32 X .44, TAPTITE II, HEX WSHR SLTD SE	4.000 EA
WD4006A01	WIRE JOINT,T&B RB-4 OR RB-44	1.000 EA
HW2501D13	KEY, 3/16 SQ X 1.375	1.000 EA
HA7000A04	KEY RETAINER 0.625 DIA SHAFTS	1.000 EA

Parts List (continued)		
Part Number	Description	Quantity
85XU0407S04	4X1/4 U DRIVE PIN STAINLESS	2.000 EA
LB1419	CONNECTION LABEL	1.000 EA
MJ1000A02	GREASE, POLYREX EM EXXON (USe 4824-15A)	0.050 LB
MG1025N19	MUNSELL 8.5BG 3.57/2.0, GLOSS 30, B/G,	0.017 GA
HA3100A13	THRUBOLT 10-32 X 7.750	4.000 EA
46BK0304C01	DBSC-VP-10-MA-287/575 VAC	1.000 EA
LB1119N	WARNING LABEL	1.000 EA
LC0006	CONNECTION LABEL	1.000 EA
NP2105L	ALUM SUPER-E UL CSA-EEV CE CC	1.000 EA
G7PA1000	PKG GRP, PRINT PK1034A06	1.000 EA
PK3082	STYROFOAM CRADLE	1.000 EA
MN416A01	TAG-INSTAL-MAINT no wire (1200/bx) 5/18	1.000 EA
PE-0000001	ZRTG PE ASSEMBLY	1.000 EA

AC Induction Motor Performance Data

Record # 32435 - Typical performance - not guaranteed values

Winding: 35WGM887-R001	Type: 3526M	Enclosure: TEFC
-------------------------------	--------------------	------------------------

Nameplate Data				575 V, 60 Hz: Single Voltage Motor	
Rated Output (HP)	1.5			Full Load Torque	4.47 LB-FT
Volts	575			Start Configuration	direct on line
Full Load Amps	1.8			Breakdown Torque	19.1 LB-FT
R.P.M.	1760			Pull-up Torque	9.34 LB-FT
Hz	60	Phase	3	Locked-rotor Torque	13.3 LB-FT
NEMA Design Code	B	KVA Code	L	Starting Current	14.6 A
Service Factor (S.F.)	1.15			No-load Current	1.09 A
NEMA Nom. Eff.	86.5	Power Factor	73	Line-line Res. @ 25°C	17 Ω
Rating - Duty	40C AMB-CONT			Temp. Rise @ Rated Load	44°C
S.F. Amps				Temp. Rise @ S.F. Load	53°C
				Locked-rotor Power Factor	52
				Rotor inertia	0.154 LB-FT ²

Load Characteristics 575 V, 60 Hz, 1.5 HP

% of Rated Load	25	50	75	100	125	150	S.F.
Power Factor	31	51	65	74	79	83	77
Efficiency	76.5	84.5	87	87.1	86.3	85.3	86.6
Speed	1791	1781	1771	1760	1748	1735	1753
Line amperes	1.15	1.28	1.49	1.75	2.06	2.38	1.94

Performance Graph at 575V, 60Hz, 1.5HP Typical performance - Not guaranteed values

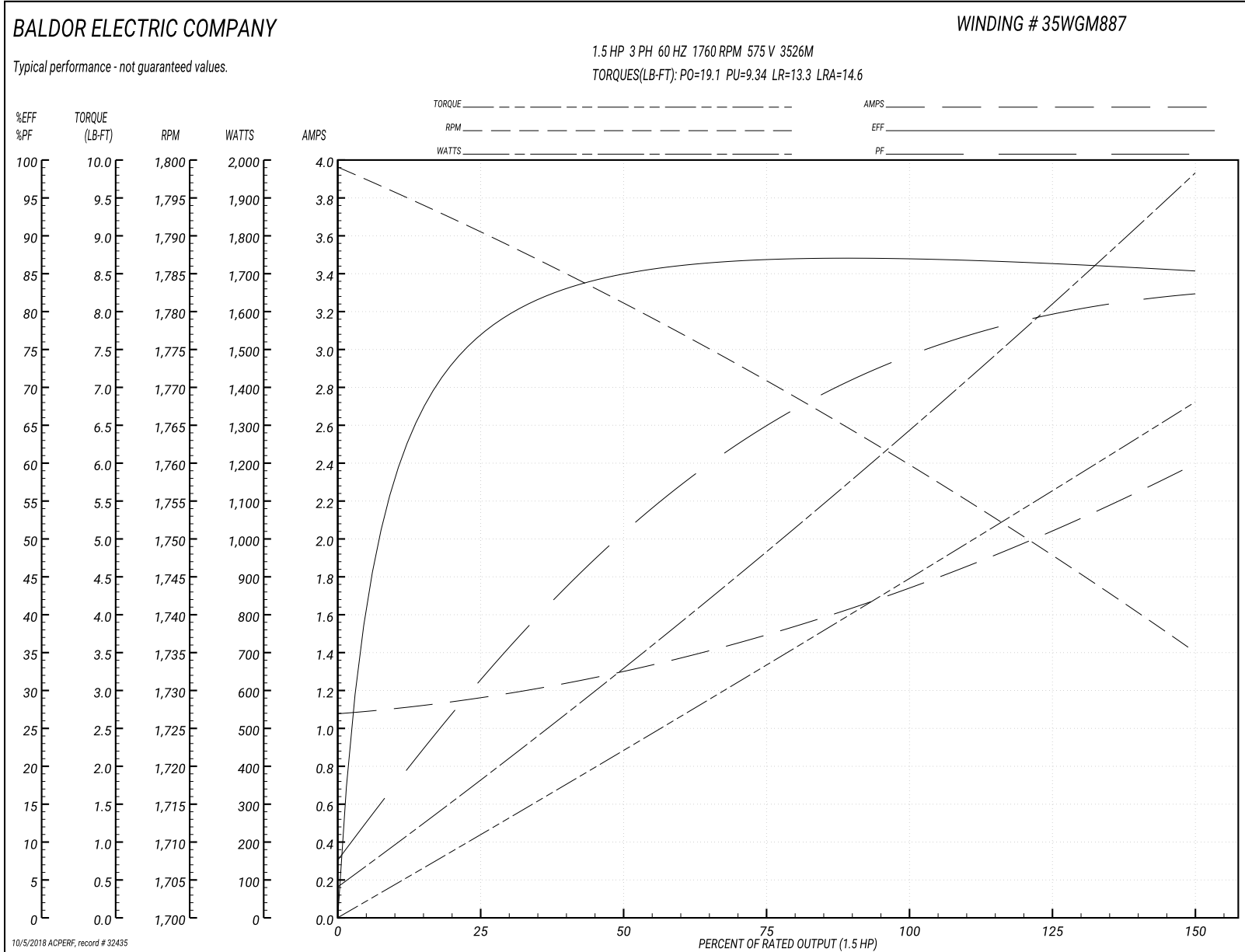

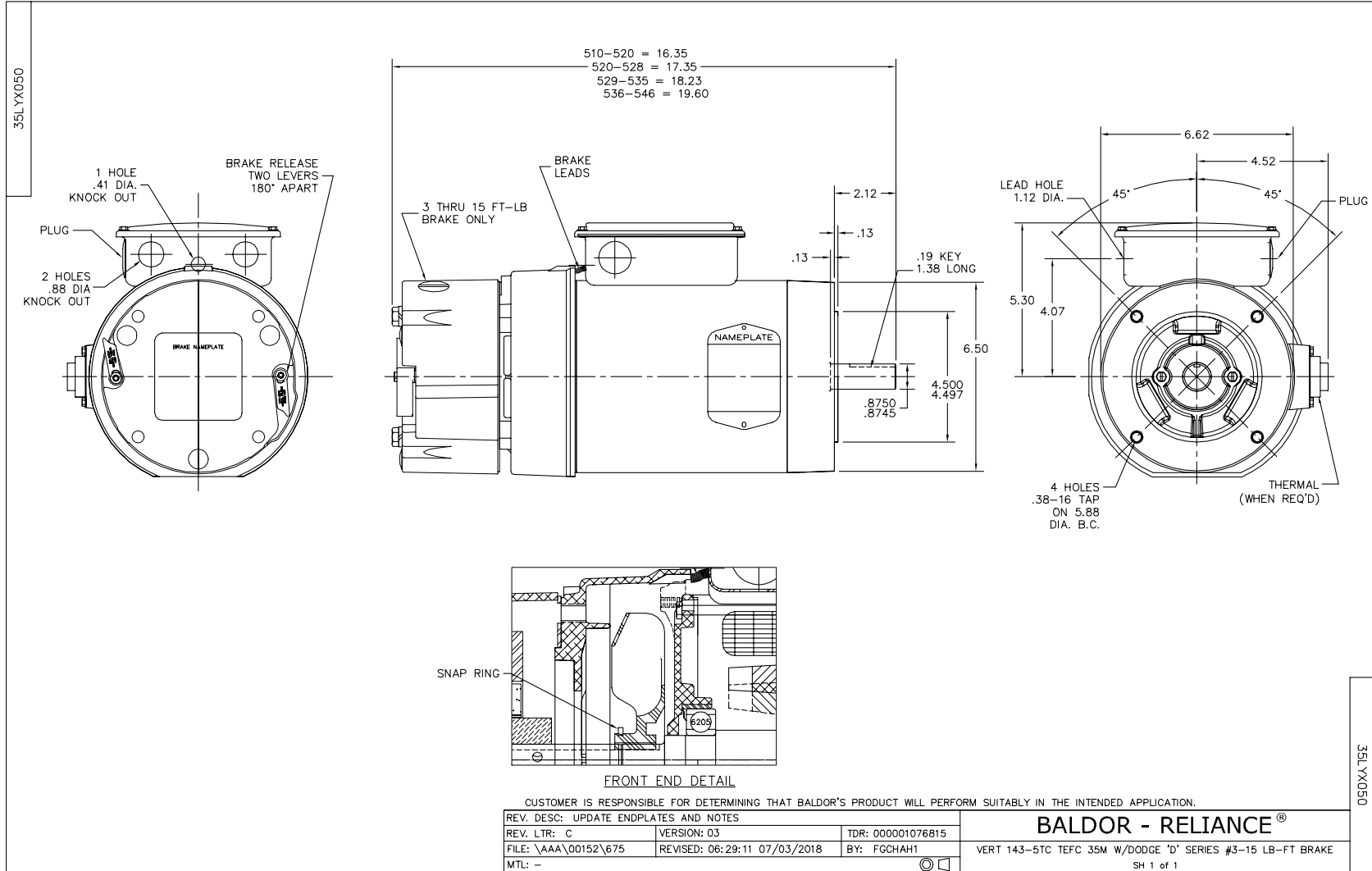

CD0006

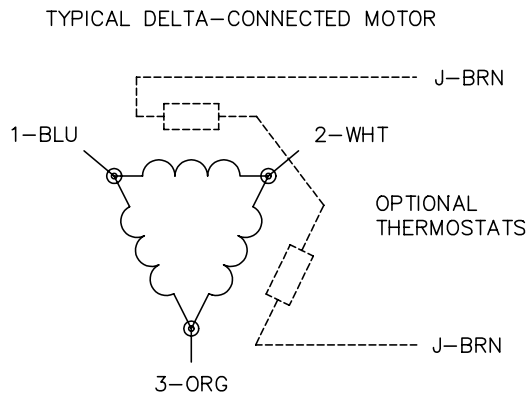

NOTES:

1. THREE LEAD MOTOR MAY BE EITHER WYE CONNECTED OR DELTA CONNECTED.
2. INTERCHANGE ANY TWO LINE LEADS TO REVERSE ROTATION.
3. OPTIONAL THERMOSTATS ARE PROVIDED WHEN SPECIFIED.
4. ACTUAL NUMBER OF INTERNAL PARALLEL CIRCUITS MAY VARY.
5. LEAD COLORS ARE OPTIONAL. LEADS MUST BE NUMBERED AS SHOWN.

REV. DESC: REVISE TO SHOW OPTIONAL COLORS			
REV. LTR: D	BY: JLP	REVISED: 01/21/99 4:02	TDR: 0171435
9000D		FILE: AAA00005141	MDL: -
		MTL: -	

BALDOR ELECTRIC Co.

3PH, SV, 3 LEADS, WYE OR DELTA CONNECTED

CD0006