

BALDOR® • RELIANCE 

Product Information Packet

VHEM3314T

15HP,3500RPM,3PH,60HZ,215HP,0744M,ODP,F1

Part Detail							
Revision:	D	Status:	PRD/A	Change #:		Proprietary:	No
Type:	AC	Elec. Spec:	07WGR867	CD Diagram:	CD0005	Mfg Plant:	
Mech. Spec:	07K218	Layout:	07LYK218	Poles:	02	Created Date:	07-06-2015
Base:	N	Eff. Date:	12-19-2017	Leads:	9#14		

Specs			
Catalog Number:	VHEM3314T	Heater Indicator:	No Heater
Enclosure:	ODP	Insulation Class:	F
Frame:	215HP	Inverter Code:	Inverter Ready
Frame Material:	Iron	KVA Code:	K
Output @ Frequency:	15.000 HP @ 60 HZ	Lifting Lugs:	Vertical Lifting Lugs
Synchronous Speed @ Frequency:	3600 RPM @ 60 HZ	Locked Bearing Indicator:	Locked Bearing
Voltage @ Frequency:	460.0 V @ 60 HZ	Motor Lead Quantity/Wire Size:	9 @ 14 AWG
	230.0 V @ 60 HZ	Motor Lead Exit:	Ko Box
XP Class and Group:	None	Motor Lead Termination:	Flying Leads
XP Division:	Not Applicable	Motor Type:	0744M
Agency Approvals:	UR	Mounting Arrangement:	F1
	CSA EEV	Power Factor:	91
	CSA	Product Family:	Weather Proof
Auxillary Box:	No Auxillary Box	Pulley End Bearing Type:	Ball
Auxillary Box Lead Termination:	None	Pulley Face Code:	P-Base
Base Indicator:	No Mounting	Pulley Shaft Indicator:	P-Base Groove & Key
Bearing Grease Type:	Polyrex EM (-20F +300F)	Rodent Screen:	None
Blower:	None	Shaft Extension Location:	Pulley End

Current @ Voltage:	16.900 A @ 460.0 V	Shaft Ground Indicator:	No Shaft Grounding
	33.800 A @ 230.0 V	Shaft Rotation:	Reversible
	35.400 A @ 208.0 V	Shaft Slinger Indicator:	Shaft Slinger
Design Code:	A	Speed Code:	Single Speed
Drip Cover:	Drip Cover	Motor Standards:	NEMA
Duty Rating:	CONT	Starting Method:	Direct on line
Electrically Isolated Bearing:	Not Electrically Isolated	Thermal Device - Bearing:	None
Feedback Device:	NO FEEDBACK	Thermal Device - Winding:	None
Front Face Code:	Standard	Vibration Sensor Indicator:	No Vibration Sensor
Front Shaft Indicator:	None	Winding Thermal 1:	None
		Winding Thermal 2:	None

Nameplate NP1267L										
CAT.NO.	VHEM3314T									
SPEC.	07K218R867G1									
HP	15									
VOLTS	230/460									
AMP	33.8/16.9									
RPM	3500									
FRAME	215HP				HZ	60			PH	3
SER.F.	1.15		CODE	K	DES	A		CL	F	
NEMA-NOM-EFF	90.2		PF	91						
RATING	40C AMB-CONT									
CC	010A				USABLE AT 208V			35.4		
DE	6309				ODE	6206				
ENCL	ODP		SN							

Parts List		
Part Number	Description	Quantity
SA303379	SA 07K218R867G1	1.000 EA
RA290502	RA 07K218R867G1	1.000 EA
HW3201A05	3/8-16 EYEBOLT	1.000 EA
09CB3002A19	CB MACH - 1.50 N.P.T. LEAD HOLE	1.000 EA
09GS1000SP	GASKET-CONDUIT BOX, 1/16 THICK LEXIDE	1.000 EA
10XN2520A12	O1/4-20X 3/4 HEX HEAD CAP	4.000 EA
HW1001A25	LOCKWASHER 1/4, ZINC PLT .493 OD, .255 I	4.000 EA
59XW2520G07	.25-20X.44,HEX SER WSHR,TAPTITE 2,GREEN	1.000 EA
07EP1200A01	FRONT END PLATE,MACH	1.000 EA
07AD2000	AIR DEFLECTOR, 307 OPEN P-BASE	1.000 EA
51XT0832A08	8-32 X 1/2 TY23 HXWS SLDSR	3.000 EA
HW1001A08	WASHER, #8 SPLT LK, ZN	3.000 EA
10XN3816A60	3/8-16 X 3-3/4 HEX HD CAPSCREW,GRADE 2,Z	2.000 EA
HW1001A38	LOCKWASHER 3/8, ZINC PLT .688 OD, .382 I	2.000 EA
HW4500A03	GREASE FITTING, .125 NPT 1610(ALEMITE) 8	1.000 EA
HW4500A17	317400 ALEMITE GREASE RELIEF	1.000 EA
HW5100A06	W2420-025 WVY WSHR (WB)	1.000 EA
07EP1505A02	SPL PU E.P. MACH, W/6309 BRG.	1.000 EA
HW4600B53	SEAL 1.688 X 2.275 X 0.312 SINGLE LIP DB	1.000 EA
HW4500A03	GREASE FITTING, .125 NPT 1610(ALEMITE) 8	1.000 EA
HW4500A17	317400 ALEMITE GREASE RELIEF	1.000 EA
HW4500A20	1/8NPT SL PIPE PLUG	1.000 EA
10XN2520A56	1/4-20X 3 1/2 HEX HD CAP X	2.000 EA
HW1001A25	LOCKWASHER 1/4, ZINC PLT .493 OD, .255 I	2.000 EA

Parts List (continued)		
Part Number	Description	Quantity
HW4600B44	V-RING SLINGER 1.500 X 1.810 X .28 VITON	1.000 EA
07FH1500A01	DRIP COVER 307 OPEN P-BASE MTRS	1.000 EA
HW3201A10	.38-16 EYEBOLT W/4.50 SHANK	2.000 EA
HW1000A38	WASHER, 3/8" FLAT, SAE Z/P	2.000 EA
10XN3816A44	3/8-16 X 2 3/4 HEX HD CAP SCREW	4.000 EA
HW1001A38	LOCKWASHER 3/8, ZINC PLT .688 OD, .382 I	4.000 EA
09CB3501SP	CONDUIT BOX LID FOR 09CB3001 & 09CB3002	1.000 EA
09GS1013SP	09 GS FOR 09CB3501 LID - LEXIDE	1.000 EA
51XW2520A12	.25-20 X .75, TAPTITE II, HEX WSHR SLTD	2.000 EA
HW1001A25	LOCKWASHER 1/4, ZINC PLT .493 OD, .255 I	2.000 EA
HW2501E17	.250 SQUARE X 1.875 LONG LOW CARBON STEE	1.000 EA
HA7000A02	KEY RETAINER RING, 1 1/8 DIA, 1 3/8 DIA	1.000 EA
85XU0407S04	4X1/4 U DRIVE PIN STAINLESS	2.000 EA
LB1386	WARNING LABEL FOR MOTORS WITH EYENUTS	1.000 EA
MJ1000A02	GREASE, POLYREX EM EXXON (USe 4824-15A)	0.050 LB
MG1025G29	WILKOFASST, 789.229, DARK CHARCOAL GRAY	0.036 GA
LC0005E01	CONN.DIA./WARNING LABEL (LC0005/LB1119N)	1.000 EA
NP1267L	SS SUPER-E LASER BLANK	1.000 EA
07PA1011	PKG GRP, 07 CAST IRON PK1181	1.000 EA
10XL3808A28	3/8 X 1 3/4" LAG SCREW	2.000 EA
MN416A01	TAG-INSTAL-MAINT no wire (1200/bx) 5/18	1.000 EA

AC Induction Motor Performance Data

Record # 57263 - Typical performance - not guaranteed values

Winding: 07WGR867-R002	Type: 0744M	Enclosure: ODP
-------------------------------	--------------------	-----------------------

Nameplate Data				460 V, 60 Hz: High Voltage Connection	
Rated Output (HP)	15			Full Load Torque	22.7 LB-FT
Volts	230/460			Start Configuration	direct on line
Full Load Amps	33.8/16.9			Breakdown Torque	74.9 LB-FT
R.P.M.	3500			Pull-up Torque	55.4 LB-FT
Hz	60	Phase	3	Locked-rotor Torque	87.1 LB-FT
NEMA Design Code	A	KVA Code	K	Starting Current	166 A
Service Factor (S.F.)	1.15			No-load Current	5.41 A
NEMA Nom. Eff.	90.2	Power Factor	91	Line-line Res. @ 25°C	0.51065 Ω
Rating - Duty	40C AMB-CONT			Temp. Rise @ Rated Load	54°C
S.F. Amps				Temp. Rise @ S.F. Load	68°C
				Locked-rotor Power Factor	31.4

Load Characteristics 460 V, 60 Hz, 15 HP

% of Rated Load	25	50	75	100	125	150	S.F.
Power Factor	60	80	88	91	92	93	92
Efficiency	89	92	92.3	91.6	90.5	89.2	90.9
Speed	3567.9	3541.3	3512.4	3478.2	3441.8	3406.2	3456
Line amperes	6.91	9.57	12.9	16.9	21.1	25.4	19.4

Performance Graph at 460V, 60Hz, 15.0HP Typical performance - Not guaranteed values

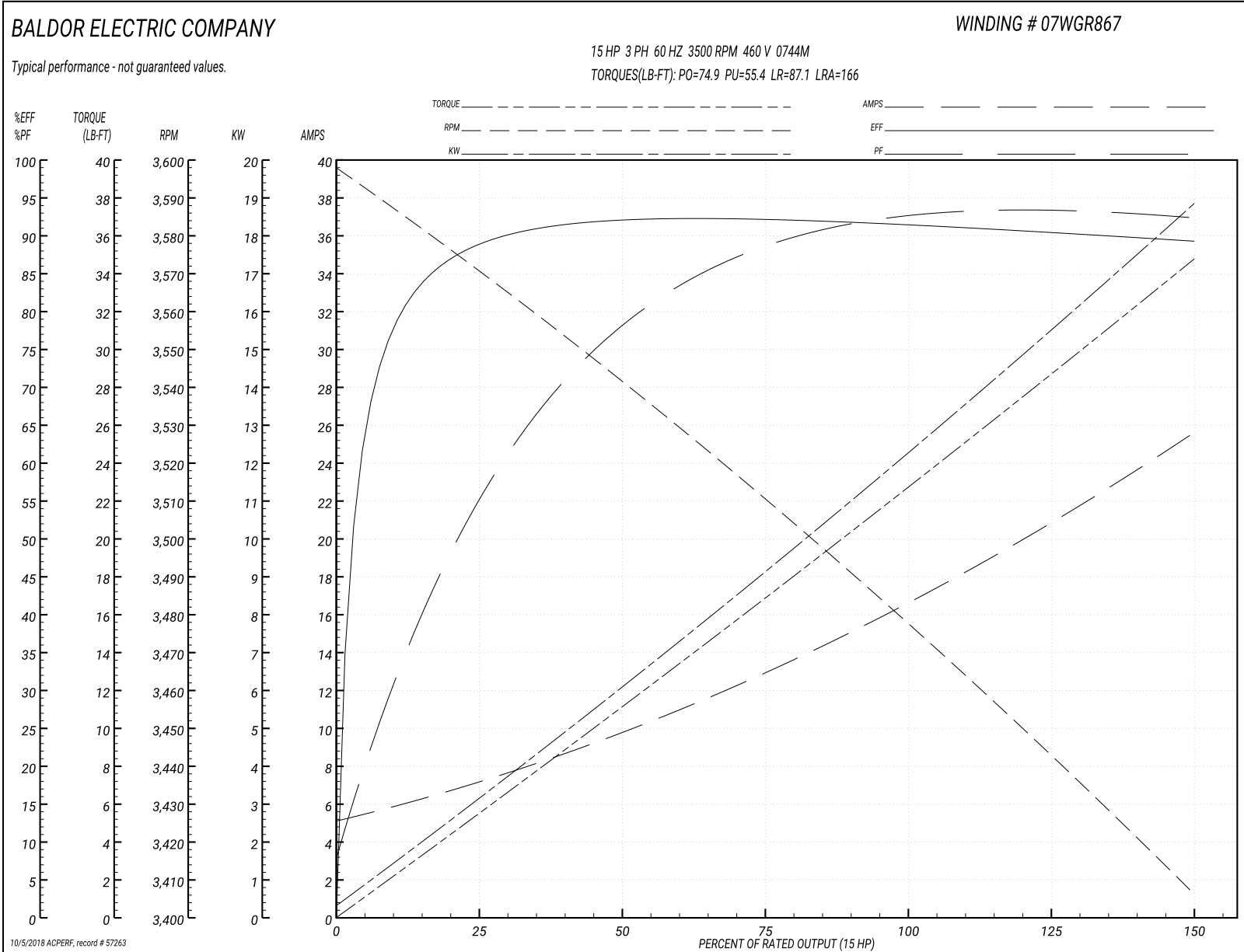

07LYK218

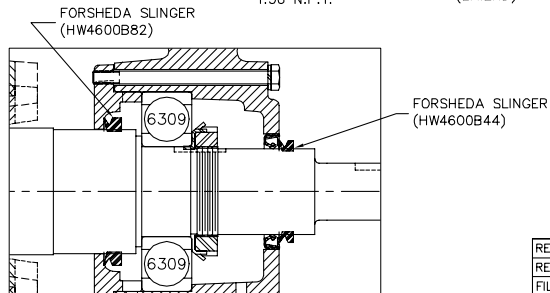
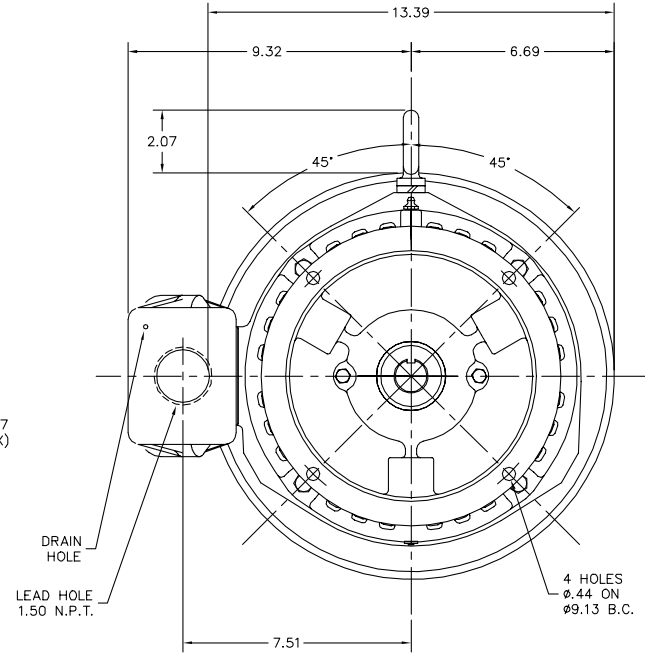
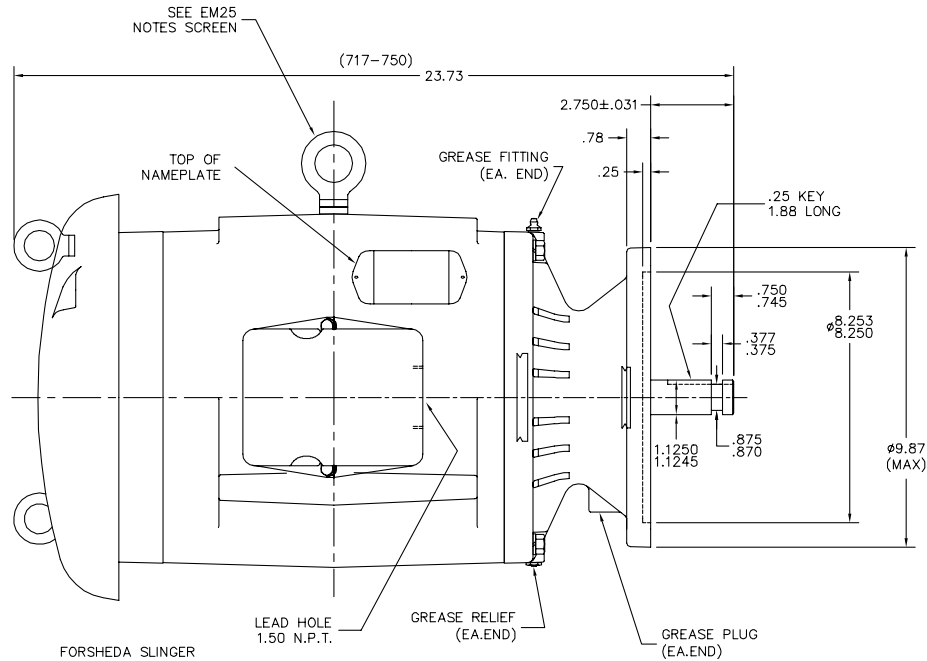

CUSTOMER IS RESPONSIBLE FOR DETERMINING THAT BALDOR'S PRODUCT WILL PERFORM SUITABLY IN THE INTENDED APPLICATION.

REV. DESC: CHANGE C-DIM	VERSION: 03	TDR: 000000821671
REV. LTR: C	REVISED: 02:54:48 10/09/2013	BY: ENKANVO
FILE: \AAA\00123\415		
MTL: -		

BALDOR

VERT OPEN 213-5HP WP (14-1) 309 PU BRG
SH 1 of 1

07LYK218

CD0005



LOW VOLTAGE
(2Y)



LINE

HIGH VOLTAGE
(1Y)



LINE

NOTES:

1. INTERCHANGE ANY TWO LINE LEADS TO REVERSE ROTATION.
2. OPTIONAL THERMOSTATS ARE PROVIDED WHEN SPECIFIED.
3. ACTUAL NUMBER OF INTERNAL PARALLEL CIRCUITS MAY BE A MULTIPLE OF THOSE SHOWN ABOVE.
4. LEAD COLORS ARE OPTIONAL. LEADS MUST ALWAYS BE NUMBERED AS SHOWN.

REV. DESC: REVISE TO SHOW OPTIONAL COLORS			
REV. LTR: E	BY: JLP	REVISED: 01/19/99 10:15	TDR: 0171435
90000		FILE: AAA00005140	MDL: -
		MTL: -	

BALDOR ELECTRIC Co.

3PH, DV, 9 LEADS

CD0005