

DATE
Jan. 14, 2011
CAT. #: VHP1004-50

OUTLINE DIMENSIONS
3-PHASE INDUCTION MOTOR

MOTOR TYPE:
AMRCNH
FRAME NO. 404TP

Pole	HP	kW	Hz	VOLT	Syn.Speed r/min(rpm)
4	100	75	50	190/380	1800

Ins	Rating	Dimension in	Approx Weight	Bearings
F	CONT.	inch	1276 lbs	DE: 6315C3 NDE: 7322B

NEMA Weather Protected TYPE I (WP I) Squirrel-cage Rotor.

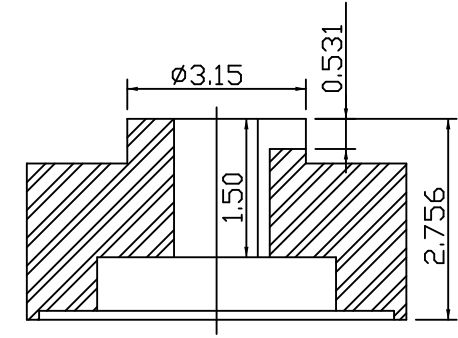
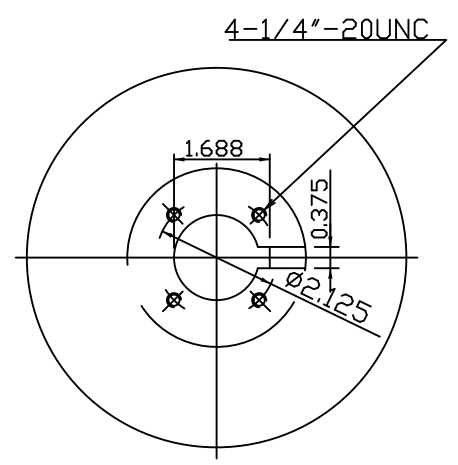
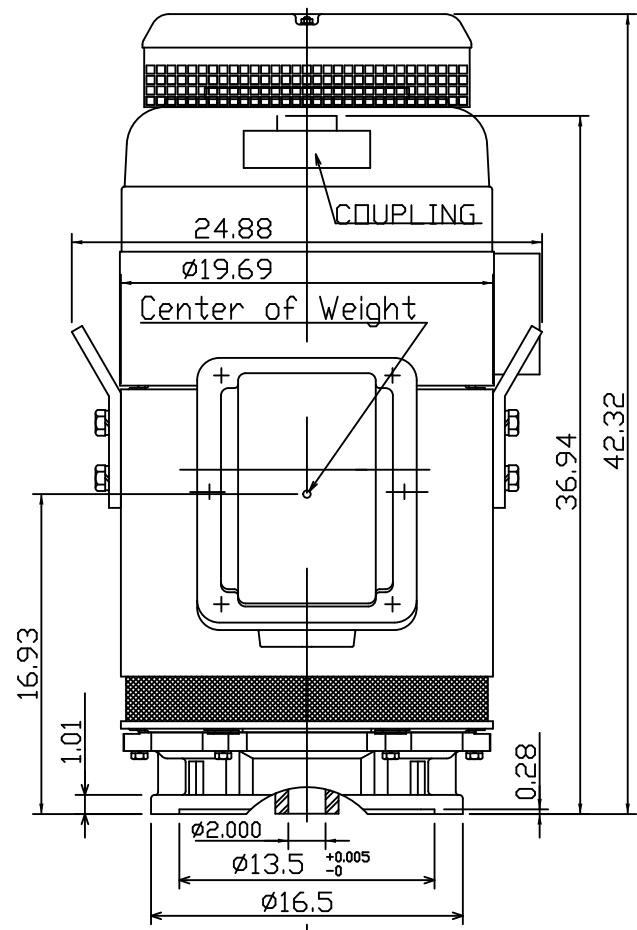

Coupling Dimension

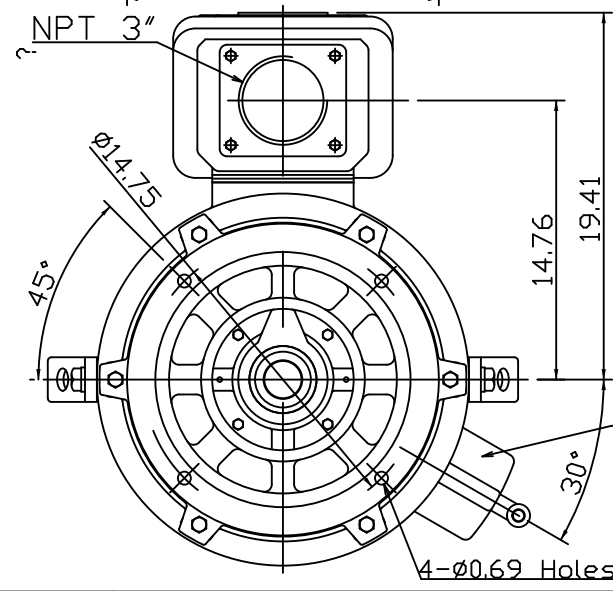

- Note:
1. Downthrust: 7900lbs
L10 - 8800 hours
 2. Rotation: C.C.W
View from Top
 3. With N.R.R.
 4. Approx Reel
Frequencies: 47 Hz
 5. Upper Bearing: Oil lube
Kind of Oil: Turbine Oil
-300SSU/100°F ISO VG68
Quantity: 1.06 Gallons

12.23.08

DWN.	???????	12 12 08
CHKD.	???????	12 23 08
APPD.	???????	12 23 08



DWG NO.
31057H811151A