

CATALOG #	TYPE	FRAME	OUTPUT		POLE	SYN. SPEED R.P.M.	VOLTAGE V.	Hz.	TIME RATING	INSULATION CLASS	SERVICE FACTOR	WEIGHT LBS
			HP	kW								
WFP1/52C	AEGP	B56C	1.5	1.12	2	3600	230/460	60	CONT.	F	1.15	39 LBS.

TOTALLY ENCLOSED FAN-COOLED TYPE. SQUIRREL CAGE MOTOR

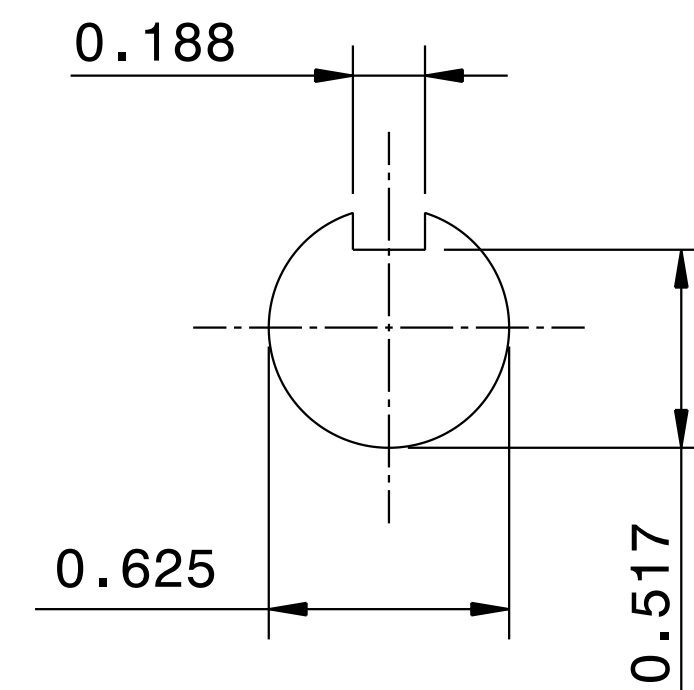
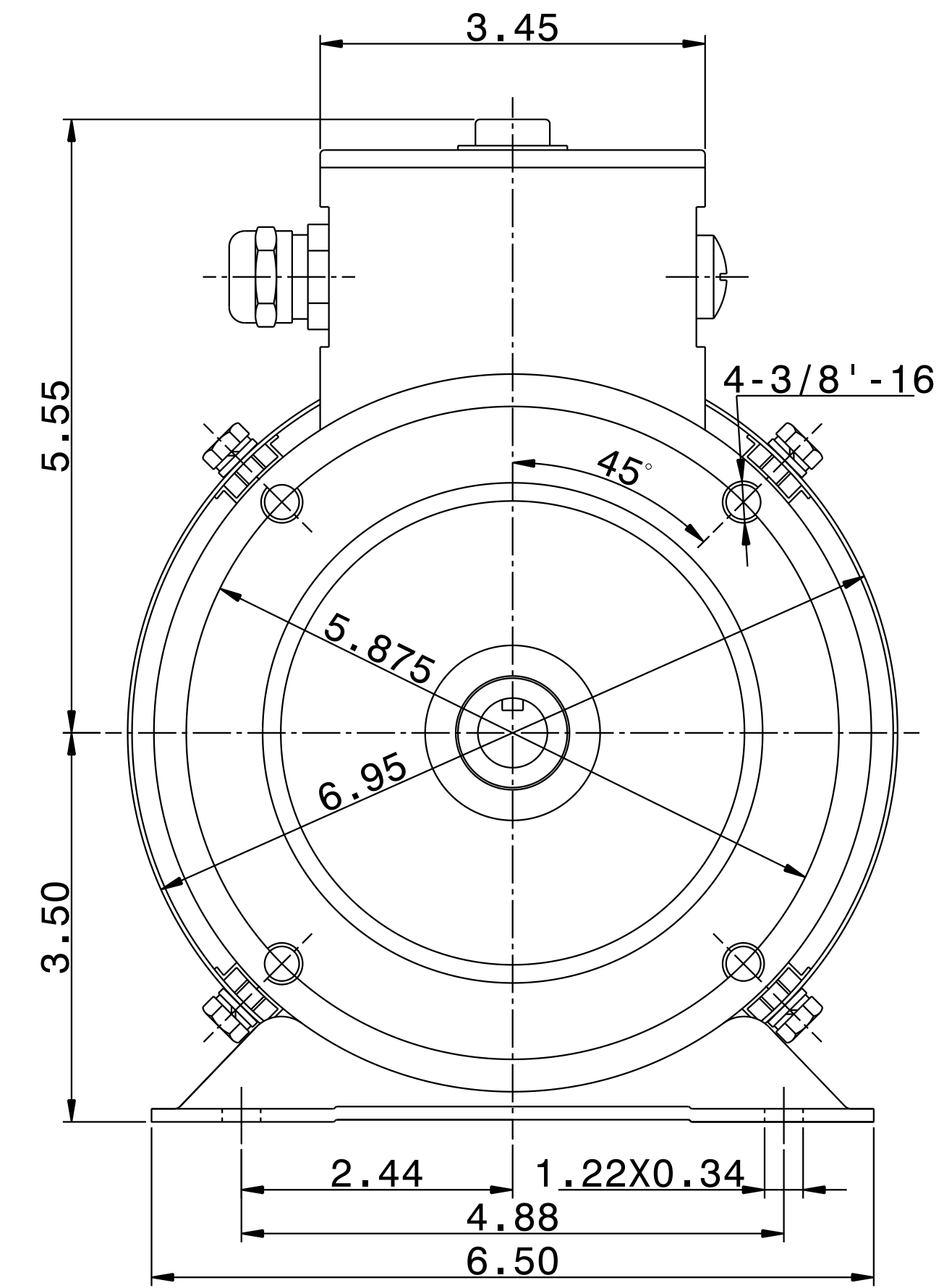
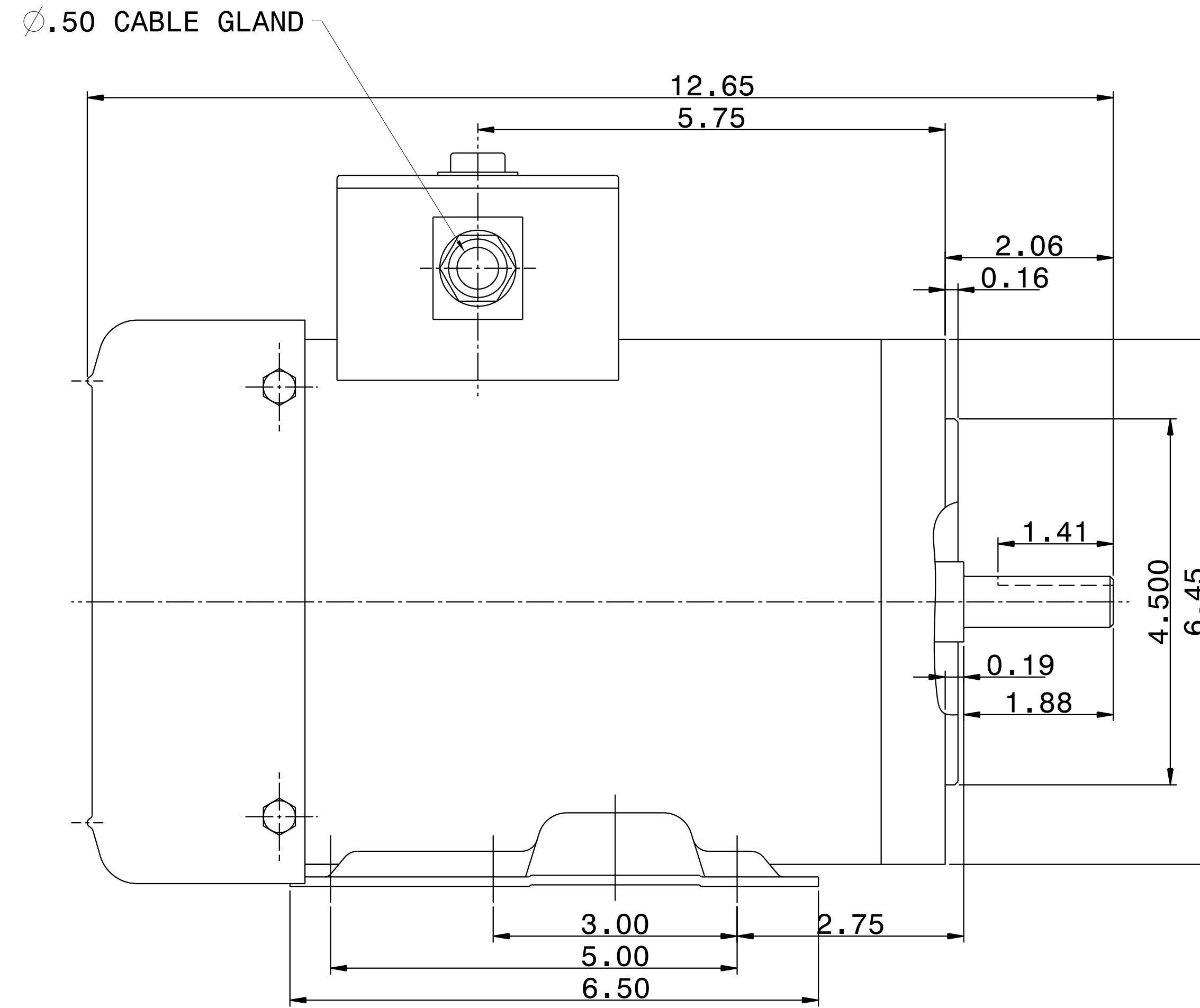

- NOTES: 1. DIMENSIONS IN INCH.
 2. ENCLOSURE: IP56.
 3. FOR DIRECT FLEXIBLE COUPLING.
 4. STAINLESS STEEL CONSTRUCTION.

REF: 31049J806230	REV. DATA			REV NO	01
	TECO Westinghouse				
	3-PHASE INDUCTION MOTOR OUTLINE DIMENSIONS			DWG NO. WFP1/52C	
	DWN T. FELPS		020713	APPD S. GROHOSKY	
TECO-WESTINGHOUSE MOTOR COMPANY			ROUND ROCK, TEXAS USA		