

SYM	REVISION	BY	DATE
A	REVISED & REDRAWN	BSK	05/20/96

SCALE: FULL

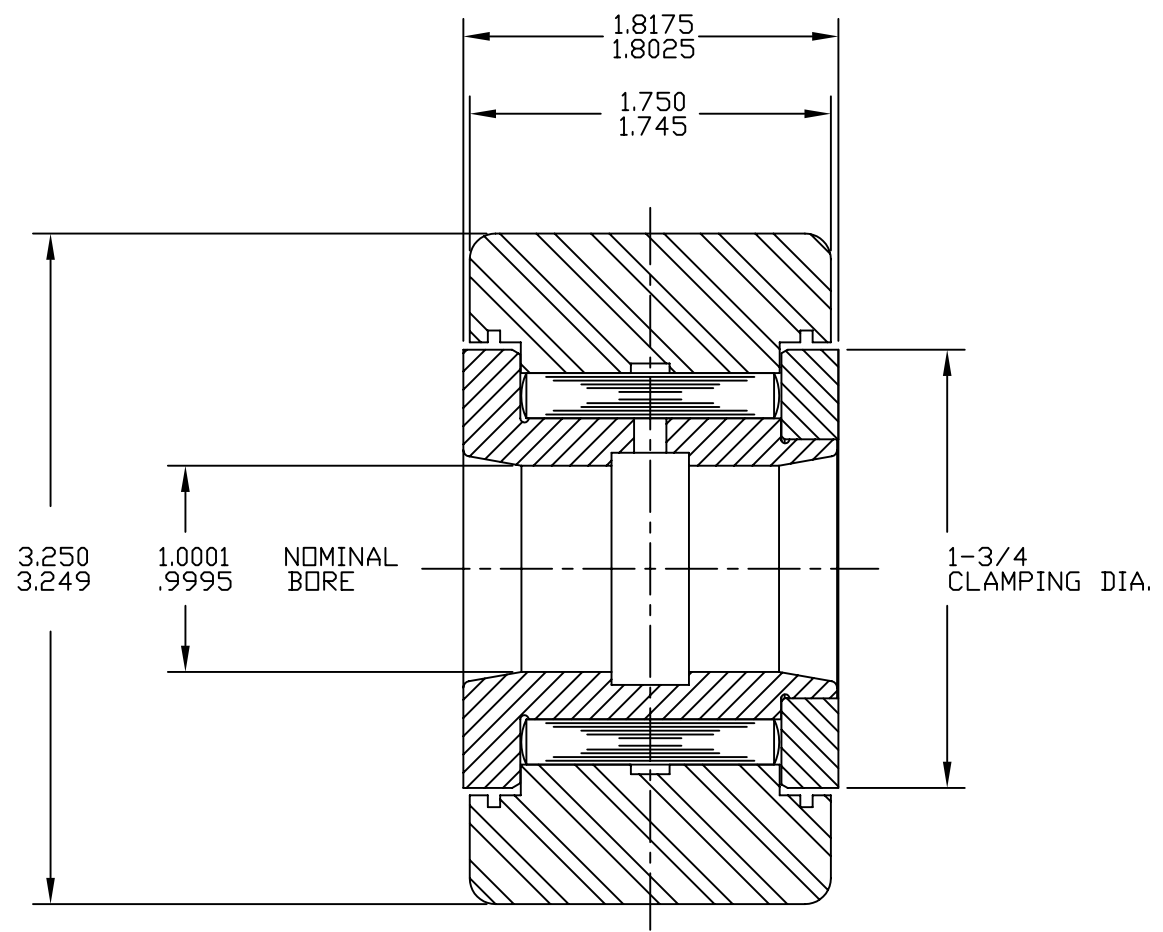

BASIC DYNAMIC CAPACITY - 14980

MAT'L: ST'D BEARING STEELS.
 BEARING PACKED WITH GENERAL PURPOSE EP GREASE.
 RELUBE PROVISIONS WILL ACCEPT 1/4" DRIVE TYPE
 FITTINGS, PLUGS SUPPLIED FOR UNUSED HOLES.

TOLERANCES	
UNLESS OTHERWISE NOTED	
FRACTIONS: ±.010	ANGLES: ±.5
2 PLACE DECIMALS (.00): ±.005	
3 PLACE DECIMALS (.000): ±.002	



ACCURATE BUSHING CO. INC.
 Manufacturers of SMITH® Bearing Product
 443 NORTH AVENUE
 Garwood, NJ 07027

PART NAME	STANDARD CAM FOLLOWER		
PART NO.	YR-3-1-4		
DRAWN BY	BSK	DATE	05/20/96
CHECKED BY		FILENAME	YRASSYS/3-1-4

YR-3-1-4