

BALDOR® • RELIANCE 

Product Information Packet

ZDM2276T

7.5HP, 1180RPM, 3PH, 60HZ, 254TC, 0954M, TEBC

Part Detail							
Revision:	AA	Status:	PRD/A	Change #:		Proprietary:	No
Type:	AC	Elec. Spec:	09WGX827	CD Diagram:	CD0005	Mfg Plant:	
Mech. Spec:	09F279	Layout:	09LYF279	Poles:	06	Created Date:	
Base:	RG	Eff. Date:	09-05-2017	Leads:	9#12		

Specs			
Catalog Number:	ZDM2276T	Insulation Class:	H
Enclosure:	TEBC	Inverter Code:	Inverter Duty
Frame:	254TC	KVA Code:	J
Frame Material:	Iron	Lifting Lugs:	Standard Lifting Lugs
Output @ Frequency:	7.500 HP @ 60 HZ	Locked Bearing Indicator:	Locked Bearing
Synchronous Speed @ Frequency:	1200 RPM @ 60 HZ	Motor Lead Quantity/Wire Size:	9 @ 12 AWG
Voltage @ Frequency:	460.0 V @ 60 HZ	Motor Lead Exit:	Ko Box
	230.0 V @ 60 HZ	Motor Lead Termination:	Flying Leads
XP Class and Group:	None	Motor Type:	0954M
XP Division:	Not Applicable	Mounting Arrangement:	F1
Agency Approvals:	CSA	Power Factor:	71
	UR	Product Family:	General Purpose
Auxillary Box:	No Auxillary Box	Pulley End Bearing Type:	Ball
Auxillary Box Lead Termination:	None	Pulley Face Code:	C-Face
Base Indicator:	Rigid	Pulley Shaft Indicator:	Standard
Bearing Grease Type:	Polyrex EM (-20F +300F)	Rodent Screen:	None
Blower:	None	Shaft Extension Location:	Pulley End
Current @ Voltage:	10.700 A @ 460.0 V	Shaft Ground Indicator:	No Shaft Grounding

	21.400 A @ 230.0 V	Shaft Rotation:	Reversible
	25.000 A @ 208.0 V	Shaft Slinger Indicator:	Shaft Slinger
Design Code:	A	Speed Code:	Single Speed
Drip Cover:	No Drip Cover	Motor Standards:	NEMA
Duty Rating:	CONT	Starting Method:	Direct on line
Electrically Isolated Bearing:	Not Electrically Isolated	Thermal Device - Bearing:	None
Feedback Device:	ENCODER	Thermal Device - Winding:	Normally Closed Thermostat
Front Face Code:	Encoder/Feedback Device	Vibration Sensor Indicator:	No Vibration Sensor
Front Shaft Indicator:	None	Winding Thermal 1:	None
Heater Indicator:	No Heater	Winding Thermal 2:	None

Nameplate NP1168L	
CAT NO	ZDM2276T
SPEC.	09F279X827Z1
FRAME	254TC HP 7.5 TE
VOLTS	230/460
MAG CUR	11/5.5 FLA 21.4/10.7
RPM	1180 RPM MAX 5000
HZ	60 PH 3 CLASS H
SER.F.	1.00 DES A SL HZ 1
NEMA-NOM-EFF	91 WK2 4.34
BLWR V	PH HZ A
RATING	40C AMB-CONT
DE BRG	6309 ODE BRG 6208
CC	010A SER.NO

Parts List		
Part Number	Description	Quantity
SA069765	SA 09F279X827Z1	1.000 EA
RA063694	RA 09F279X827Z1	1.000 EA
HW1002A63	0ASHER, 5/8 HI-COLLAR SPRLCKWASHER	1.000 EA
09CB3002SP	CB W/1.38 LEAD HOLE FOR 37, 39, 307 & 30	1.000 EA
09GS1000SP	GASKET-CONDUIT BOX, 1/16 THICK LEXIDE	1.000 EA
10XN2520K12	1/4-20 X.75 GRD 5	2.000 EA
HW1001A25	LOCKWASHER 1/4, ZINC PLT .493 OD, .255 I	2.000 EA
WD1000B16	T&B CX70TN TERMINAL	1.000 EA
59XW2520G07	.25-20X.44,HEX SER WSHR,TAPTITE 2,GREEN	1.000 EA
09EP1300A12	ENDPLATE, MACH	1.000 EA
09EP1100A74	FR. E.P. TEBC/TENV W/THRU SHAFT ENCODER	1.000 EA
HA4051A00	PLASTIC CAP FOR GREASE FITTING	1.000 EA
HW4600B44	V-RING SLINGER 1.500 X 1.810 X .28 VITON	1.000 EA
XY3816A12	3/8-16 FINISHED NUT	4.000 EA
HW1001A38	LOCKWASHER 3/8, ZINC PLT .688 OD, .382 I	4.000 EA
51XW2520A12	.25-20 X .75, TAPTITE II, HEX WSHR SLTD	4.000 EA
HA1005A12	SLINGER, OD 2.50, ID 1.433, 208 BRG	1.000 EA
10XN2520K12	1/4-20 X.75 GRD 5	1.000 EA
HW1001A25	LOCKWASHER 1/4, ZINC PLT .493 OD, .255 I	1.000 EA
HW5100A08	W3118-035 WVY WSHR (WB)	1.000 EA
10XN2520K28	1/4-20 X 1.75" HX HD SCRWGRADE 5, ZINC P	2.000 EA
HW1001A25	LOCKWASHER 1/4, ZINC PLT .493 OD, .255 I	2.000 EA
10XN2520K36	1/4-20 X 2.25" HX HD SCRWGRADE 5, ZINC P	4.000 EA
HW1001A25	LOCKWASHER 1/4, ZINC PLT .493 OD, .255 I	4.000 EA

Parts List (continued)		
Part Number	Description	Quantity
HA4051A00	PLASTIC CAP FOR GREASE FITTING	1.000 EA
HA3113A01	THRUBOLT 3/8-16X14.875	4.000 EA
HW1001A38	LOCKWASHER 3/8, ZINC PLT .688 OD, .382 I	4.000 EA
09FH4002	FAN HSG TEBC 309 MTR F1 & F2 AB	1.000 EA
HA6353A01	MTG. BRACKET 309 FRAME FAN HOUSING	4.000 EA
10XN3118K08	5/16-18 X .50 GRADE #5, STL, ZINC PLATE	4.000 EA
33CB3002	CONDUIT BOX, CAST	1.000 EA
34CB4500SP	CONDUIT BOX LID, STAMPED	1.000 EA
34GS1001	GASKET, STD CONDUIT BOX LID (LEXIDE)	1.000 EA
51XW0832A07	8-32 X .44, TAPTITE II, HEX WSHR SLTD SE	4.000 EA
RM1022A02	GROMMET .875 ID 1.00 OD .12 WALL,VENDOR#	1.000 EA
51XN0832A12	8-32 HEX SLOT WSHR HD MACH SC GRADE 2, Z	2.000 EA
HW1001A08	WASHER, #8 SPLT LK, ZN	4.000 EA
XY0832A02	8-32 HEX NUT	2.000 EA
WD4101A09	STIMPSON D3560, .875 DIA. HOLE PLUG	1.000 EA
09CB3501SP	CONDUIT BOX LID FOR 09CB3001 & 09CB3002	1.000 EA
09GS1013SP	09 GS FOR 09CB3501 LID - LEXIDE	1.000 EA
51XW2520A12	.25-20 X .75, TAPTITE II, HEX WSHR SLTD	2.000 EA
HW2501G25	KEY, 3/8 SQ X 2.875	1.000 EA
LB1115N	LABEL,LIFTING DEVICE (ON ROLLS)	1.000 EA
LB1009N	LABEL,ROTATION DIRECTION (ON ROLLS)	1.000 EA
HW4500A05	1669B ALEM/UNIV860 GR FTG X	1.000 EA
HW4500A17	317400 ALEMITE GREASE RELIEF	1.000 EA
HA4054	SHORT T-DRAIN FITTING, .125" N.P.T.	1.000 EA

Product Information Packet: ZDM2276T - 7.5HP,1180RPM,3PH,60HZ,254TC,0954M,TEBC

MJ1000A02	GREASE, POLYREX EM EXXON (USe 4824-15A)	0.080 LB
HW4500A03	GREASE FITTING, .125 NPT 1610(ALEMITE) 8	1.000 EA
HW4500A17	317400 ALEMITE GREASE RELIEF	1.000 EA
HA4054	SHORT T-DRAIN FITTING, .125" N.P.T.	1.000 EA
EF5000	VENTURI/GRILLE KIT FOR 307/309 TEBC MOTO	1.000 EA
MG1000G27	MED CHARCOAL METALLIC GREY 400-0096	0.050 GA
85XU0407S04	4X1/4 U DRIVE PIN STAINLESS	2.000 EA
ENC02BC-B2	ENCDR KIT TEBC W/OEHS35A09 W/BLIND SHAFT	1.000 EA
MN416A01	TAG-INSTAL-MAINT no wire (1200/bx) 5/18	1.000 EA
WD4101A08	STIMPSON #D3557,1.188 DIA. HOLE PLUG	1.000 EA
LC0005E02	SPL CONN.DIA./WARN.LABEL(LC0005/LB1119)	1.000 EA
NP1168L	ALUM VEC UL CSA CC	1.000 EA
42PA1010	PACKAGING GROUP, PRINT PK1151A06	1.000 EA

AC Induction Motor Performance Data

Record # 20707 - Typical performance - not guaranteed values

Winding: 09WGX827-R002	Type: 0954M	Enclosure: TEFC
-------------------------------	--------------------	------------------------

Nameplate Data				460 V, 60 Hz: High Voltage Connection	
Rated Output (HP)	7.5			Full Load Torque	32.4 LB-FT
Volts	230/460			Start Configuration	direct on line
Full Load Amps	21.4/10.7			Breakdown Torque	99.2 LB-FT
R.P.M.	1180			Pull-up Torque	39.4 LB-FT
Hz	60	Phase	3	Locked-rotor Torque	57.8 LB-FT
NEMA Design Code	A	KVA Code	J	Starting Current	69.7 A
Service Factor (S.F.)	1			No-load Current	5.84 A
NEMA Nom. Eff.	91	Power Factor	71	Line-line Res. @ 25°C	0.89 Ω
Rating - Duty	40C AMB-CONT			Temp. Rise @ Rated Load	31°C
				Locked-rotor Power Factor	26
				Rotor inertia	4.34 LB-FT ²

Load Characteristics 460 V, 60 Hz, 7.5 HP

% of Rated Load	25	50	75	100	125	150
Power Factor	32	52	63	71	73	75
Efficiency	83	89.7	91.5	91.5	91.8	91.2
Speed	1196	1192	1189	1184	1179	1173
Line amperes	6.34	7.49	8.87	10.7	12.9	15.7

Performance Graph at 460V, 60Hz, 7.5HP Typical performance - Not guaranteed values

BALDOR ELECTRIC COMPANY

WINDING # 09WGX827

Typical performance - not guaranteed values.

7.5 HP 3 PH 60 HZ 1180 RPM 460 V 0954M

TORQUES(LB-FT): PO=99.2 PU=39.4 LR=57.8 LRA=69.7

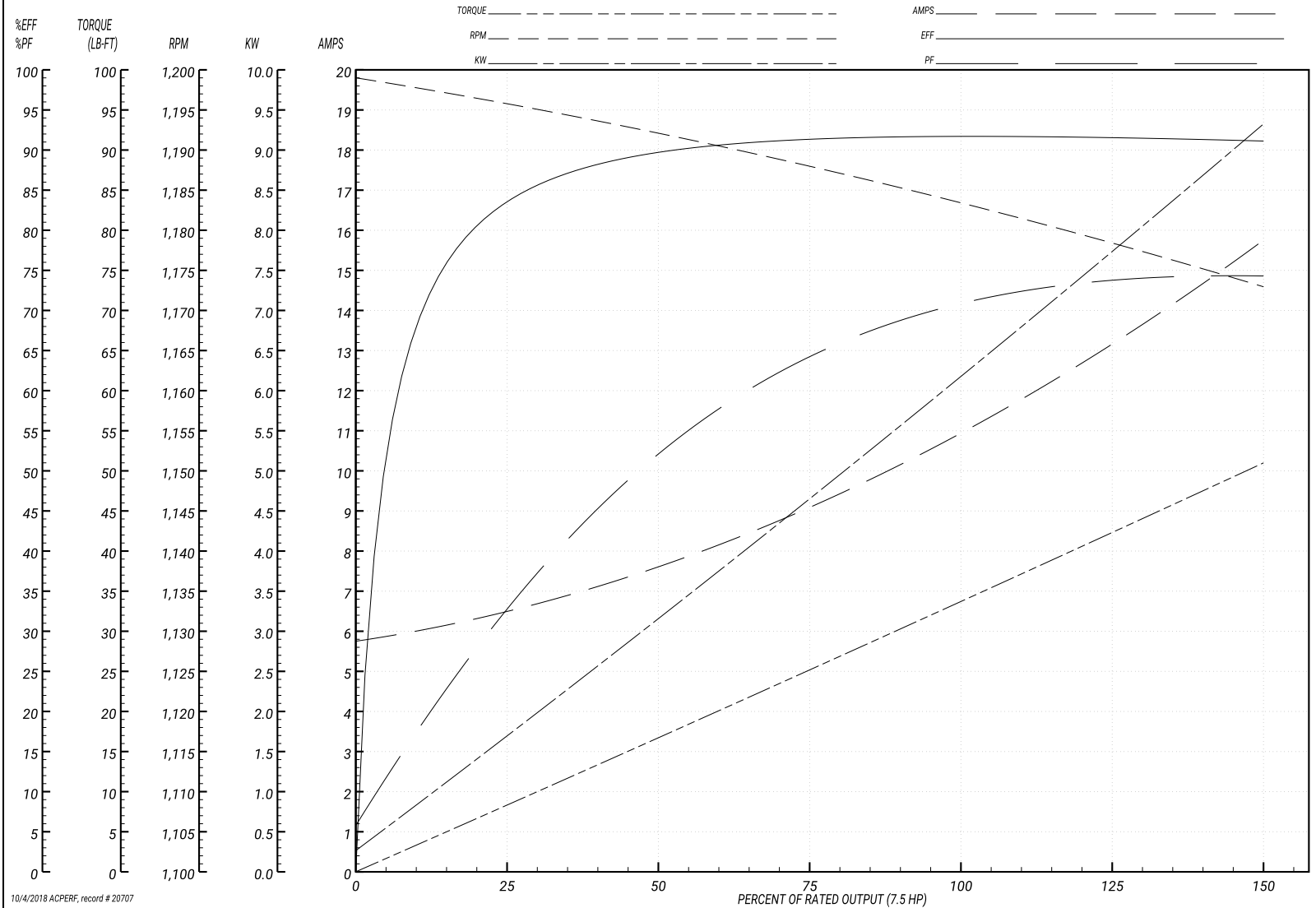

10/4/2018 ACPERF, record # 20707

09LYF279

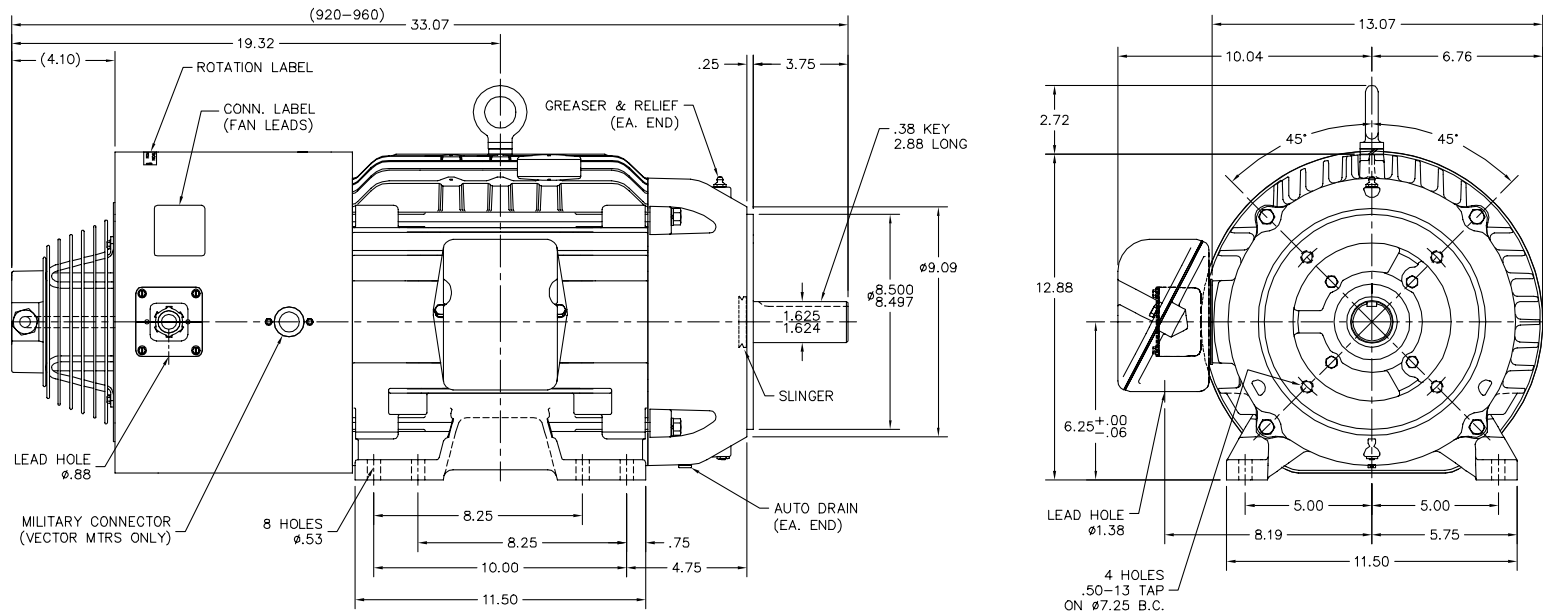

09LYF279

CUSTOMER IS RESPONSIBLE FOR DETERMINING THAT BALDOR'S PRODUCT WILL PERFORM SUITABLY IN THE INTENDED APPLICATION.

REV. DESC: UPDATE DRAIN FITTING		
REV. LTR: E	VERSION: 02	TDR: 000000857729
FILE: \AAA\00070\812	REVISED: 09:18:48 06/11/2014	BY: ENNINDO
MTL: -	☐	

BALDOR

HORZ TEBC 254-6TC INV/VEC W/THRU SH ENCODER DESIGN

SH 1 of 1

CD0005



LOW VOLTAGE
(2Y)

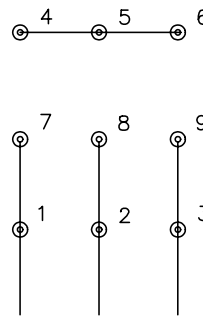

LINE

HIGH VOLTAGE
(1Y)

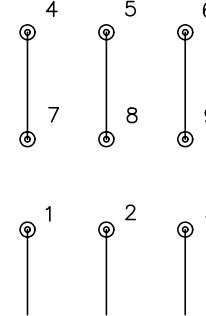

LINE

NOTES:

1. INTERCHANGE ANY TWO LINE LEADS TO REVERSE ROTATION.
2. OPTIONAL THERMOSTATS ARE PROVIDED WHEN SPECIFIED.
3. ACTUAL NUMBER OF INTERNAL PARALLEL CIRCUITS MAY BE A MULTIPLE OF THOSE SHOWN ABOVE.
4. LEAD COLORS ARE OPTIONAL. LEADS MUST ALWAYS BE NUMBERED AS SHOWN.

REV. DESC: REVISE TO SHOW OPTIONAL COLORS			
REV. LTR: E	BY: JLP	REVISED: 01/19/99 10:15	TDR: 0171435
9000D		FILE: AAA00005140	MDL: -
		MTL: -	

BALDOR ELECTRIC Co.

3PH, DV, 9 LEADS

CD0005